

**PACH**  
BUILDING FUTURES

# FOCUS! CORE! BUILDING FUTURES!

Apach Industrial's humble beginnings began in 1993 in Taichung, Taiwan known worldwide for its machining and tool making prowess. Superior technology in metals and CNC machining in conjunction with a strong Taiwanese supply base made this area thrive with quality manufacturers of pneumatic and power tools. To this day the world's top name brands still build their high value quality tools here in Taiwan.

Apach is proud of the fact that we were one of the first companies from Taiwan to introduce an 18 gauge angled brad nailer into the United States construction market in the late 90's. Apach was also one of the first to make our industrial stapler line a brand name known and trusted in the North American market

The vision of Apach as the People's tool has always been at the core of what we do. Professional craftsman making furniture, framing homes, making cabinets and using our tools to build the things that we use each and every day is the reason why we focus on dependability and safety. Over the years we realized maximum customer satisfaction is not just a quality management system goal it's a commitment to society. It's our commitment to Building Futures!



## INDEX PAGES

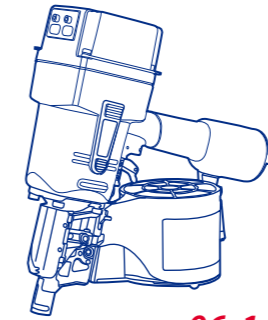

### Coil Nailers

p06-14

CN-57.1	Industrial Coil Nailer	06
CN-57E	Industrial Coil Nailer	06
CN-65.1	Industrial Coil Nailer	07
CN-70.1	Industrial Coil Nailer	07
CN-70E	Industrial Coil Nailer	08
CN-70E2	Industrial Coil Nailer	08
CN-83.1	Industrial Coil Nailer	09
CN-83E	Industrial Coil Nailer	09
CN-83F	Industrial Coil Nailer	10
CN-90.1L	Industrial Coil Nailer	10
CN-90.1LC	Industrial Coil Nailer	11
CN-90LH	Industrial Coil Nailer	11
CN-100E	Industrial Coil Nailer	12
CN-100EPAL	Industrial Coil Nailer	12
CN-130E	Industrial Coil Nailer	13
CN-50P.1	Industrial Coil Nailer	13
CN-565S	Industrial Coil Nailer	14
RN-45E2	Roofing Coil Nailer	14

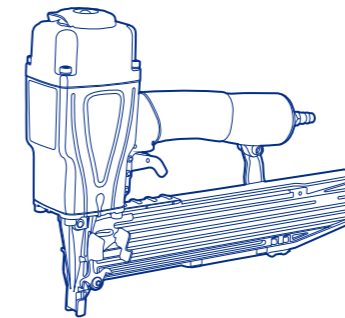

### Framing Nailers

p15-18

AN9021-1	21 Degree Strip Framing Nailer	16
AN9034-1	34 Degree Strip Framing Nailer	17
AN-10034-1	34 Degree Strip Framing Nailer	17
AN-13021E	21 Degree Strip Nailer	18
AN-16021E	21 Degree Strip Nailer	18

### Finish Nailers

p19-27

PT-630	23 GA Micro Pinner	20
PT-635	23 GA Micro Pinner	20
LMF-40LAC	21 GA Mini Brad Nailer	21
LNF-32AC	18 GA Brad Nailer	21
LNF-50AC	18 GA Brad Nailer	22
LNF-50AC-1	18 GA Brad Nailer	22
LU-50FAC	2-in-1 Combination Tool	23
LT-50LAC	15/16 GA Finish Nailer, Light Duty	23
LT-50LLAC	15/16 GA Finish Nailer & Concrete Nailer, Light Duty	24
LT-1650	15/16 GA Finish Nailer & Concrete Nailer, Heavy Duty	24
LT-1650AC	15/16 GA Finish Nailer	25
LT-1664AC	15/16GA Finish Nailer	25
LT-1664EB	16 GA Finish Nailer	26
DA-64E1	DA Series Angle Finish Nailer	26
LHT-38	14 GA Concrete Nail	27
LHT-64	14 GA Concrete Nailer, Heavy Duty	27

### Staplers

p28-58

LU-SJK16F	SJK Series Fine Wire Stapler	29	LU-9040KT	18 GA Narrow Crown Stapler, Heavy Duty	43
LU-7116F	71 Series Fine Wire Stapler	30	LU-9225AC	18 GA Medium Crown Stapler	43
LU-7116AC	71 Series Fine Wire Stapler	30	LU-9240LAC	18 GA Medium Crown Stapler, Light Duty	44
LU-7116LAC	71 Series Fine Wire Stapler, Long Nose	31	LU-9240HAC	18 GA Medium Crown Stapler, Heavy Duty	44
LU-7116.1AUTO	71 Series Auto-Fire Staplers	31	LU-G25AC	18 GA Medium Crown Stapler	45
LU-7116.1AUTO/LM	71 Series Auto-Fire Staplers, Long Magazine	32	LU-G32HAC	18 GA Medium Crown Stapler, Long Nose	45
LU-1416AC	14 Series Fine Wire Stapler	32	LU-G40LAC	18 GA Medium Crown Stapler	46
LU-2316F	23 Series Fine Wire Stapler	33	LU-50040LAC	18 GA Wide Crown Stapler	46
LU-9716F	97 Series Fine Wire Stapler	33	LU-9438AC	18 GA Wide Crown Stapler	47
LU-9725AC	97 Series Fine Wire Stapler	34	LU-851LC1	16 GA Medium Crown Stapler	48
LU-8416AC	84 Series Fine Wire Stapler	34	LU-851F2	16 GA Medium Crown Stapler	49
LU-8016F	80 Series Fine Wire Stapler	35	LU-851F2-FM	16 GA Medium Crown Stapler	49
LU-8016AC.1	80 Series Fine Wire Stapler	35	LU-864F	16 GA Medium Crown Stapler	50
LU-8016.1AUTO	80 Series Auto-Fire Staplers	36	LU-851KGF2	18 GA Medium Crown Stapler	50
LU-8016.1AUTO/LM	80 Series Auto-Fire Staplers, Long Magazine	36	LU-864KGF	18 GA Medium Crown Stapler	51
LU-8025AC	80 Series Fine Wire Stapler	37	LU-951F2	16 GA Medium Crown Stapler	51
LU-425JAC	4J Series Stapler	37	LU-964F	16 GA Medium Crown Stapler	52
LU-1016F	10F Series Fine Wire Stapler	38	LU-1580F	15 GA Medium Crown Stapler	52
LU-1016J	10J Series Fine Wire Stapler	38	LU-1438	14 GA Wide Crown Stapler, Heavy Duty	53
LU-1016AUTO	10J Series Auto-Fire Stapler	39	LU-2438.1	16 GA Wide Crown Stapler, Light Duty	53
LU-1025JAC	10J Series Stapler	39	LU-2438.1-WS	16 GA Walking Stick Stapler	54
LU-5018AC	50 Series Fine Wire Stapler	40	LU-2538.1	16 GA Wide Crown Stapler, Light Duty	55
LU-9025AC	18 GA Narrow Crown Stapler	40	LU-2538.1-WS	16 GA Walking Stick Stapler	55
LU-9032AC	18 GA Narrow Crown Stapler	41	LU-2538	16 GA Wide Crown Stapler, Heavy Duty	56
LU-9040LAC	18 GA Narrow Crown Stapler, Light Duty	41	LU-2638.1	16 GA Wide Crown Stapler, Light Duty	56
LU-9040LAD	18 GA Narrow Crown Stapler, Light Duty	42	LU-2638.1-WS	16 GA Walking Stick Stapler	57
LU-9040HAC	18 GA Narrow Crown Stapler, Heavy Duty	42	LU-2638	16 GA Wide Crown Stapler, Heavy Duty	57

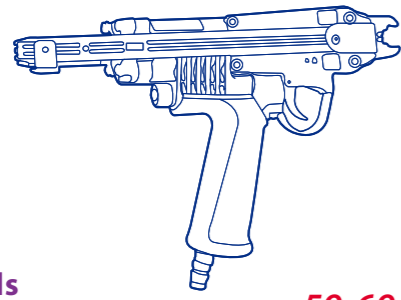

### Specialty Tools

p59-69

LPHC	Pneumatic Hog Ring Tools	60
LPHCN	Pneumatic Hog Ring Tools	61
Mattress Stapler	Mattress Stapler	62
NP-50	Nail Puncher	63
NP-57E	Nail Puncher	63
NP-70E	Nail Puncher	64
CF-15AA	Corrugated Fastener Tool	65
CF-15AP	Corrugated Fastener Tool	65
PTS-8400	Palm Nailer	66
AMC-38	Metal Connector Nailer	67
LU-8016FP	2-in-1 Medium & Narrow Crown Stapler for Polymer Staples	67
CN-70CL	Pneumatic Clinch Nailer	68
Autotec Modular Series	Auto Modular For Jumbo Coil Nails	69

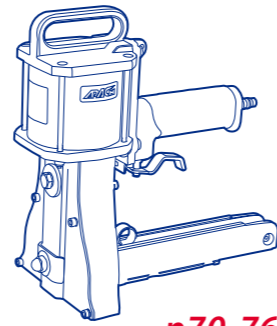

### Carton Closing Tools

p70-76

Strip Staples	Carton Closing Staplers	71
Strip Staples	Carton Closing Staplers	72
Coil Series	Carton Closing Staplers	73
LPB & LPS	Pneumatic Foot Bottomers	74
Jumbo Series	Jumbo Carton Closing Staplers	75
Specialty Tools	Specialty Tools - Pneumatic Stapling Pliers	76

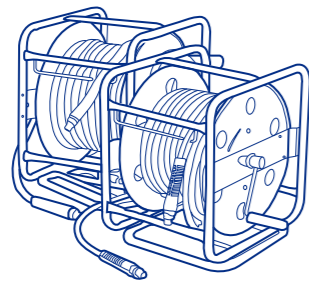



### Accessories

p77

Hose Reels

77

### Common Applications

 Roofing, Carpentry	 Cabinets, Furniture, Light wood assembly
 Framing, Joiner	 Packaging, Crating, Pallets
 Upholstery, Furniture, Bedding	 Siding, Sheathing, Paneling, Fencing
 Door, Window, Trimming, Picture Frames, Building Components	 Industrial, Pre-Fabricated Housing

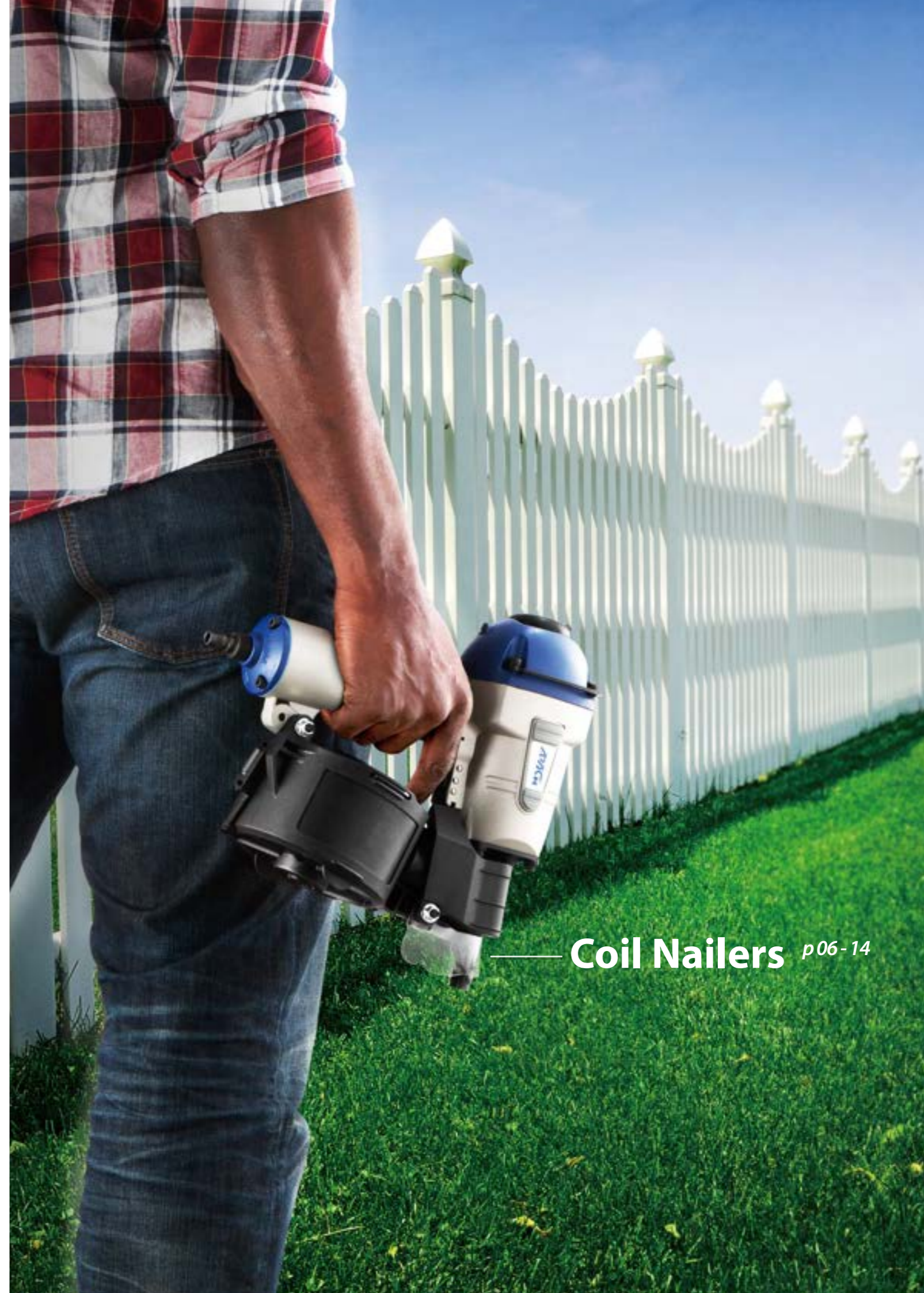

Coil Nailers p06-14

# Coil Nailers

Industrial Coil Nailer



## CN-57.1

### Features

- Ergonomic Design, Well Balanced
- Powerful, Rapid Nailing Performance
- Adjustable Safety Yoke Available
- Body Protectors Equipped

### Fasteners

- 15° Flat Wire Collated Nails
- Length: 1 - 2 1/4" (25 - 57mm)
- Shank Diameter: .083 - .090" (2.1 - 2.3mm)
- Shank Type: Smooth, Ring & Screw

### Applications



### Tool Specifications

Weight	Dimensions (LxWxH)	Operating Pressure	Load Capacity
2.5 kgs	285 x 135 x 285mm	5 - 7 kg / cm <sup>2</sup>	300 - 400 nails
5.5 lbs	11 7/32 x 5 5/16 x 11 7/32"	70 - 100 psi	300 - 400 nails

## CN-57.1

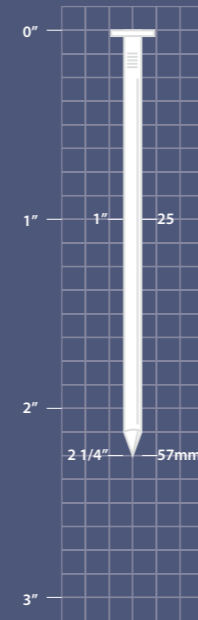

# Coil Nailers

Industrial Coil Nailer



## CN-65.1

### Features

- Ergonomic Design, Well Balanced
- Powerful, Rapid Nailing Performance
- Body Protectors Equipped
- Top Exhaust Cap Available

### Fasteners

- 15° Flat Wire Collated Nails
- Length: 1 3/8" - 2 3/4" (35 - 65mm)
- Shank Diameter: .090 - .113" (2.3 - 2.9mm)
- Shank Type: Smooth, Ring & Screw

### Applications



### Tool Specifications

Weight	Dimensions (LxWxH)	Operating Pressure	Load Capacity
2.82 kgs	302 x 129 x 308mm	5 - 7 kg / cm <sup>2</sup>	wire 225-300
6.2 lbs	11.9 x 5 x 12.1"	70 - 100 psi	wire 225-300

## CN-65.1

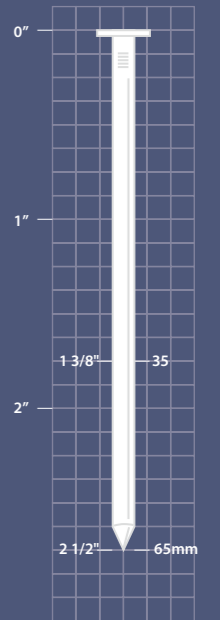

# Coil Nailers

Industrial Coil Nailer



## CN-57E

### Features

- Ergonomic Design, Well Balanced
- Powerful, Rapid Nailing Performance
- 360° Adjustable Exhaust Port
- Body Protectors Equipped
- Adjustable Safety Yoke Available

### Fasteners

- 15° Flat Wire Collated Nails
- Length: 1 - 2 1/4" (25 - 57mm)
- Shank Diameter: .083 - .090" (2.1 - 2.3mm)
- Shank Type: Smooth, Ring & Screw

### Applications



### Tool Specifications

Weight	Dimensions (LxWxH)	Operating Pressure	Load Capacity
2.5 kgs	285 x 135 x 285mm	5 - 7 kg / cm <sup>2</sup>	300 - 400 nails
5.5 lbs	11 7/32 x 5 5/16 x 11 7/32"	70 - 100 psi	300 - 400 nails

## CN-57E

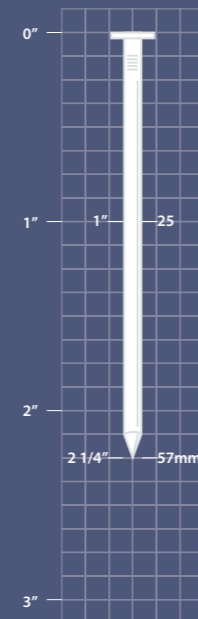

# Coil Nailers

Industrial Coil Nailer



## CN-70.1

### Features

- Ergonomic Design, Well Balanced
- Powerful, Rapid Nailing Performance
- Body Protectors Equipped
- Nail Punchers for Pallet Recycling Available
- Top Exhaust Cap Available

### Fasteners

- 15° Flat Wire Collated Nails
- Length: 1 3/4" - 2 3/4" (45 - 70mm)
- Shank Diameter: .090 - .113" (2.3 - 2.9mm)
- Shank Type: Smooth, Ring & Screw

### Applications



### Tool Specifications

Weight	Dimensions (LxWxH)	Operating Pressure	Load Capacity
3.5 Kgs	320 x 125 x 318mm	5 - 7 kg / cm <sup>2</sup>	225 - 300 Nails
7.7 lbs	12 5/8 x 4 7/8 x 12 1/2"	70 - 100 psi	225 - 300 Nails

## CN-70.1

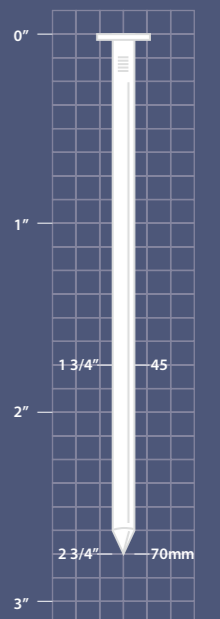

# Coil Nailers

Industrial Coil Nailer



## CN-70E

### Features

- Ergonomic Design, Well Balanced
- Powerful, Rapid Nailing Performance
- Body Protectors Equipped
- Nail Punchers for Pallet Recycling Available
- Top Exhaust Cap Available

### Fasteners

- 15° Flat Wire Collated Nails
- Length: 1 3/4" - 2 3/4" (45 - 70mm)
- Shank Diameter: .090 - .113" (2.3 - 2.9mm)
- Shank Type: Smooth, Ring & Screw

### Applications



### Tool Specifications

Weight	Dimensions (LxWxH)	Operating Pressure	Load Capacity
3.62 Kgs	320 x 125 x 318mm	5 - 7 kg / cm <sup>2</sup>	225 - 300 Nails
7.96 lbs	12 5/8 x 4 7/8 x 12 1/2"	70 - 100 psi	225 - 300 Nails

## CN-70E

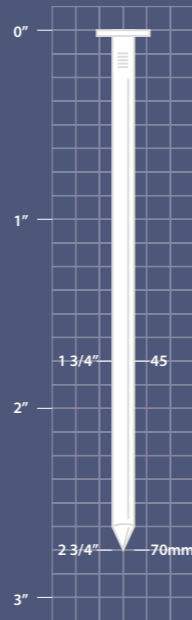

# Coil Nailers

Industrial Coil Nailer



## CN-83.1

### Features

- Ergonomic Design, Well Balanced
- Powerful, Rapid Nailing Performance
- Body Protectors Equipped
- Adjustable Safety Yoke Available

### Fasteners

- 15° Flat Wire Collated Nails
- Length: 2 - 3 1/4" (50 - 83mm)
- Shank Diameter: .099 - .131" (2.5 - 3.3mm)
- Shank Type: Smooth, Ring & Screw

### Applications



### Tool Specifications

Weight	Dimensions (LxWxH)	Operating Pressure	Load Capacity
3.8 kgs	313 x 129 x 349mm	5 - 7 kg / cm <sup>2</sup>	225 - 300 nails
8.36 lbs	12 5/16 x 5 1/16 x 13 3/4"	70 - 100 psi	225 - 300 nails

## CN-83.1

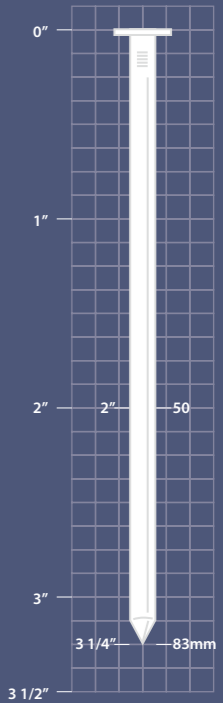

# Coil Nailers

Industrial Coil Nailer



## CN-70E2

### Features

- With 2-pc Nose Joint Guide
- Ergonomic Design, Well Balanced
- Powerful, Rapid Nailing Performance
- Body Protectors Equipped
- Top Exhaust Cap Available

### Fasteners

- 15° Flat Wire Collated Nails
- Length: 1 3/4" - 2 3/4" (45 - 70mm)
- Shank Diameter: .090 - .113" (2.3 - 2.9mm)
- Shank Type: Smooth, Ring & Screw

### Applications



### Tool Specifications

Weight	Dimensions (LxWxH)	Operating Pressure	Load Capacity
3.62 kgs	320 x 125 x 318mm	5 - 7 kg / cm <sup>2</sup>	225 - 300 nails
7.96 lbs	12 5/8 x 4 7/8 x 12 1/2"	70 - 100 psi	225 - 300 nails

## CN-70E2

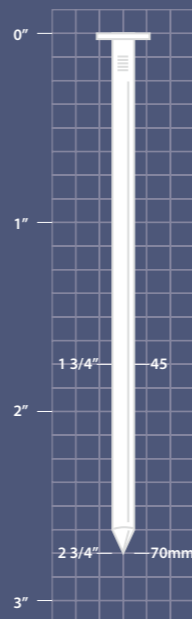

# Coil Nailers

Industrial Coil Nailer



## CN-83E

### Features

- Ergonomic Design, Well Balanced
- Powerful, Rapid Nailing Performance
- 360° Adjustable Exhaust Port
- Body Protectors Equipped
- Adjustable Safety Yoke Available

### Fasteners

- 15° Flat Wire Collated Nails
- Length: 2 - 3 1/4" (50 - 83mm)
- Shank Diameter: .099 - .131" (2.5 - 3.3mm)
- Shank Type: Smooth, Ring & Screw

### Applications



### Tool Specifications

Weight	Dimensions (LxWxH)	Operating Pressure	Load Capacity
3.7 kgs	313 x 129 x 349mm	5 - 7 kg / cm <sup>2</sup>	225 - 300 nails
8.2 lbs	12 5/16 x 5 1/16 x 13 3/4"	70 - 100 psi	225 - 300 nails

## CN-83E

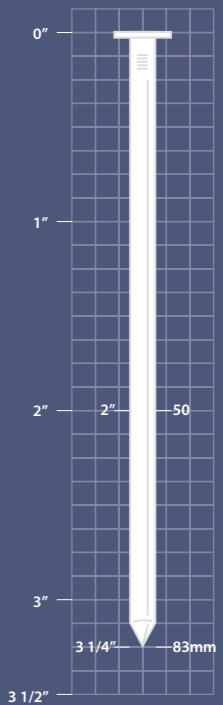

# Coil Nailers

Industrial Coil Nailer



## CN-83F

### Features

- Ergonomic Design, Well Balanced
- Powerful, Rapid Nailing Performance
- Front Exhaust Top Cap
- Body Protectors Equipped
- Adjustable Safety Yoke Available

### Fasteners

- 15° Flat Wire Collated Nails
- Length: 2 - 3 1/4" (50 - 83mm)
- Shank Diameter: .099 - .131" (2.5 - 3.3mm)
- Shank Type: Smooth, Ring & Screw

### Applications



### Tool Specifications

Weight	Dimensions (LxWxH)	Operating Pressure	Load Capacity
3.7 kgs	313 x 129 x 349mm	5 - 7 kg / cm <sup>2</sup>	225 - 300 nails
8.2 lbs	12.5/16 x 5 1/16 x 13 3/4"	70 - 100 psi	225 - 300 nails

## CN-83F

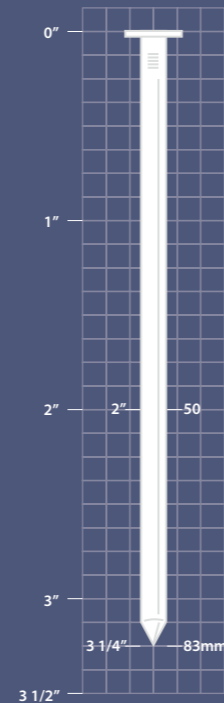

# Coil Nailers

Industrial Coil Nailer



## CN-90.1LC

### Features

- Ergonomic Design, Well Balanced
- Powerful, Rapid Nailing Performance
- Anti-double fire mechanism available
- Sequential Trigger Available
- Adjustable safety yoke Available(depth 9mm)

### Fasteners

- 15° Flat Wire Collated Nails
- Length: 2 - 3 1/2" (50 - 90mm)
- Shank Diameter: .099 - .131" (2.5 - 3.3mm)
- Shank Type: Smooth, Ring & Screw

### Applications



### Tool Specifications

Weight	Dimensions (LxWxH)	Operating Pressure	Load Capacity
3.74 kgs	347 x 142 x 365mm	5 - 7 kg / cm <sup>2</sup>	225 - 300 nails
8.23 lbs	13.66 x 5.59 x 14.37"	70 - 100 psi	225 - 300 nails

## CN-90.1LC

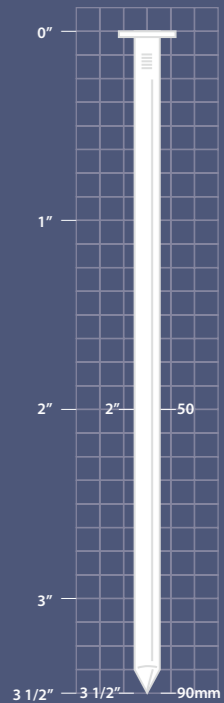

# Coil Nailers

Industrial Coil Nailer



## CN-90.1L

### Features

- Ergonomic Design, Well Balanced
- Powerful, Rapid Nailing Performance
- Sequential Trigger Available

### Fasteners

- 15° Flat Wire Collated Nails
- Length: 2 - 3 1/2" (50 - 90mm)
- Shank Diameter: .099 - .131" (2.5 - 3.3mm)
- Shank Type: Smooth, Ring & Screw

### Applications



### Tool Specifications

Weight	Dimensions (LxWxH)	Operating Pressure	Load Capacity
3.74 kgs	347 x 142 x 365mm	5 - 7 kg / cm <sup>2</sup>	225 - 300 nails
8.23 lbs	13.66 x 5.59 x 14.37"	70 - 100 psi	225 - 300 nails

## CN-90.1L

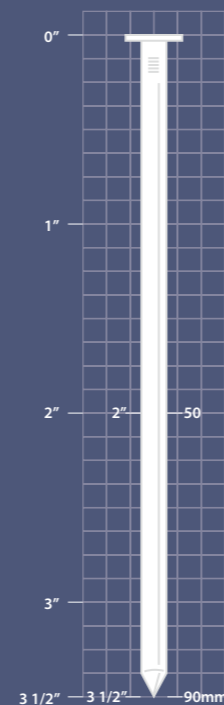

# Coil Nailers

Industrial Coil Nailer



## CN-90LH

### Features

- Ergonomic Design, Well Balanced
- Powerful, Rapid Nailing Performance

### Fasteners

- 15° Flat Wire Collated Nails
- Length: 2 - 3 1/2" (50 - 90mm)
- Shank Diameter: .099 - .131" (2.5 - 3.3mm)
- Shank Type: Smooth, Ring & Screw

### Applications



### Tool Specifications

Weight	Dimensions (LxWxH)	Operating Pressure	Load Capacity
4.32 kgs	360 x 130 x 350mm	5 - 7 kg / cm <sup>2</sup>	225 - 300 nails
9.51 lbs	14.3/16 x 5 1/16 x 13 3/4"	70 - 100 psi	225 - 300 nails

## CN-90LH

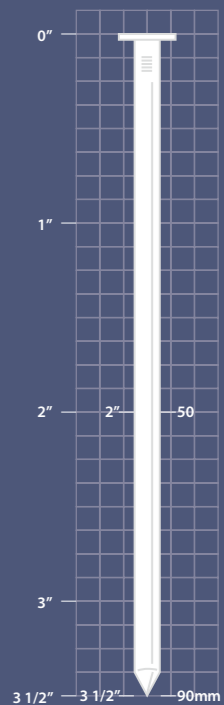

# Coil Nailers

Industrial Coil Nailer



## CN-100E

### Features

- Ergonomic Design, Well Balanced
- Powerful, Rapid Nailing Performance
- Removable Auxiliary Side Handle
- Body Protectors Equipped

### Fasteners

- 15° Flat Wire Collated Nails
- Length: 2 1/2 - 4" (65 - 100mm)
- Shank Diameter: .099 - .131" (2.5 - 3.3mm)
- Shank Type: Smooth, Ring & Screw

### Applications



### Tool Specifications

Weight	Dimensions (LxWxH)	Operating Pressure	Load Capacity
5.36 kgs	355 x 141 x 412mm	5-7 kg / cm <sup>2</sup>	200 - 300 nails
11.8 lbs	14 x 5 1/2 x 16 7/32"	70 - 100 psi	200 - 300 nails

## CN-100E

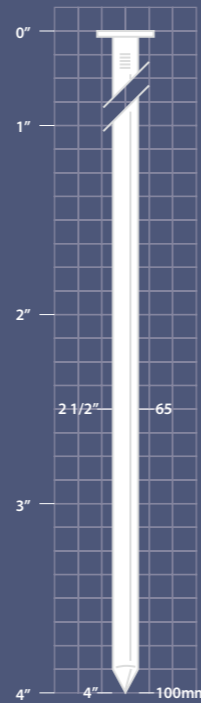

# Coil Nailers

Industrial Coil Nailer



## CN-130E

### Features

- Ergonomic Design, Well Balanced
- Powerful, Rapid Nailing Performance
- Sequential Trigger
- Removable Auxiliary Side Handle
- Body Protectors Equipped

### Fasteners

- 15° Flat Wire Collated Nails
- Length: 3 1/2 - 5 1/8" (90 - 130mm)
- Shank Diameter: .131 - .150" (3.3 - 3.8mm)
- Shank Type: Smooth, Ring & Screw

### Applications



### Tool Specifications

Weight	Dimensions (LxWxH)	Operating Pressure	Load Capacity
5.7 kg	354 x 149 x 473mm	5.5 - 8 kg / cm <sup>2</sup>	180 nails
12.54 lbs	14 x 5 7/8 x 18 5/8"	80 - 120 psi	180 nails

## CN-130E

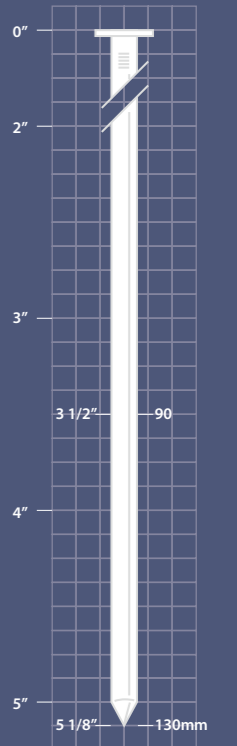

# Coil Nailers

Industrial Coil Nailer



## CN-100EPAL

### Features

- Ergonomic Design, Well Balanced
- Powerful, Rapid Nailing Performance
- Removable Auxiliary Side Handle
- Body Protectors Equipped

### Fasteners

- 15° Flat Wire Collated Nails
- Length: 2 1/2 - 3 1/2" (65 - 90 mm)
- Head Diameter: .322" (8.2 mm)
- Shank Diameter: .134" (3.4 mm) Shank: Ring

### Applications



### Tool Specifications

Weight	Dimensions (LxWxH)	Operating Pressure	Load Capacity
5.36 kgs	355 x 141 x 412mm	5-7 kg / cm <sup>2</sup>	180 pcs
11.8 lbs	14 x 5 1/2 x 16 7/32"	70 - 100 psi	180 pcs

## CN-100EPAL

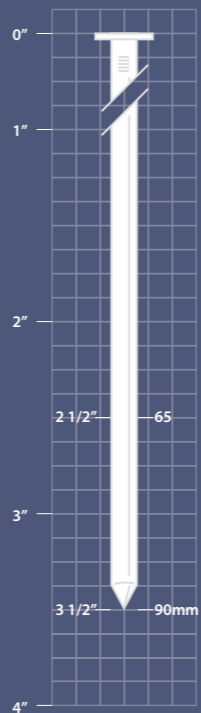

# Coil Nailers

Industrial Coil Nailer



## CN-50P.1

### Features

- Accepts Both Wire & Plastic Sheet Collated Nails
- Powerful Motor with Minimum Recoil
- Tool-Free Depth Adjustment
- Light-Weight Only 1.6 kg (3.5 lbs)
- Clear Magazine Cover to See Nail Quantity
- Removable No-Mar Rubber Pad with Holder in Magazine
- Sequential Trigger Available

### Fasteners

- 15° Wire Or Plastic Sheet Collated Nails
- Length: Wire Collated: 1-1/8 - 2" (27 - 50mm)  
Plastic Collated: 1 - 2" (25 - 50mm)
- Shank Diameter: Wire Collated: .072 - .083" (1.8-2.1mm)  
Plastic Collated: .063 - .083" (1.6-2.1mm)
- Shank Type: Smooth, Screw & Ring

### Applications



### Tool Specifications

Weight	Dimensions (LxWxH)	Operating Pressure	Load Capacity
1.6 kgs	251 x 117 x 282mm	5 - 7 kg / cm <sup>2</sup>	wire 250 - 400
3.5 lbs	9.9 x 4.6 x 11.1"	70 - 100 psi	plastic sheet 200

## CN-50P

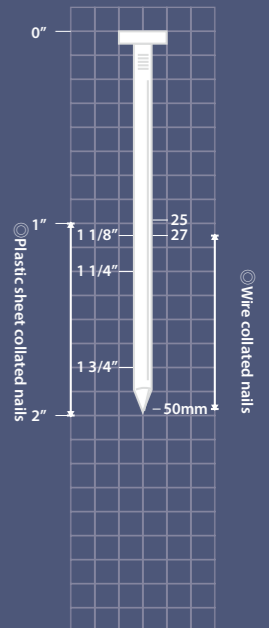

## Coil Nailers

Industrial Coil Nailer



### CN-565S

#### Features

- Accepts Both Wire & Plastic Sheet Collated Nails
- Powerful Motor Drives 250 to 400 Nails Continuously
- Tool Free Depth Adjustment
- Sequential Trigger Available

#### Fasteners

- 15° Wire & Plastic Sheet Collated Nails
- Length: Wire: 1 3/4 - 2 1/2" (45 - 65mm)  
Plastic Sheet: 1 1/4 - 2 1/2" (32 - 65mm)
- Ø .090 - .099" (2.3 - 2.5mm)

#### Applications



#### Tool Specifications

Weight	Dimensions (LxWxH)	Operating Pressure	Load Capacity
2.68 kgs	280 x 130 x 320mm	5-7 kg / cm <sup>2</sup>	wire 250 - 400
5.9 lbs	11 x 5 x 12.6"	70 - 100 psi	plastic sheet 200

### CN-565S

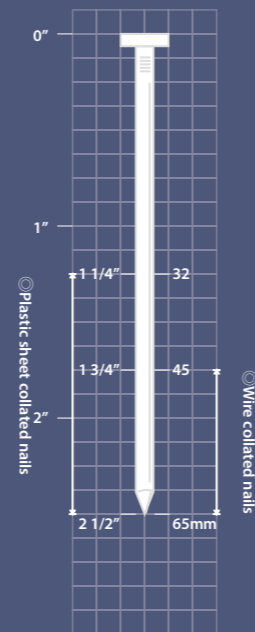

## Coil Nailers

Roofing Coil Nailer



### RN-45E2

#### Features

- Ergonomic Design, Well Balanced
- Low Noise Low Vibration, Less Fatigue
- See-Thru Side Loading Magazine
- Sequential Trigger Available
- 360° Adjustable Exhaust Port
- Body Protectors Equipped
- Rapid Nailing Performance
- Carbide Insert in Safety Tip for Increased Wear Resistance Against Tar Paper
- Tool-Free Depth Adjustment
- Integrated Magnet in Nose to Hold The Last Nail
- Durable Metal Shingle Guide
- Nice Belt Hook

#### Fasteners

- Length: 7/8 - 1 3/4" (22 - 45mm)
- Shank Diameter: .120" (3.05mm)

#### Applications



#### Tool Specifications

Weight	Dimensions (LxWxH)	Operating Pressure	Load Capacity
2.6 kgs	269 x 118 x 283mm	5 - 7 kg / cm <sup>2</sup>	120 nails
5.7 lbs	10 5/8 x 4 5/8 x 11 1/8"	70 - 100 psi	120 nails

### RN-45E2

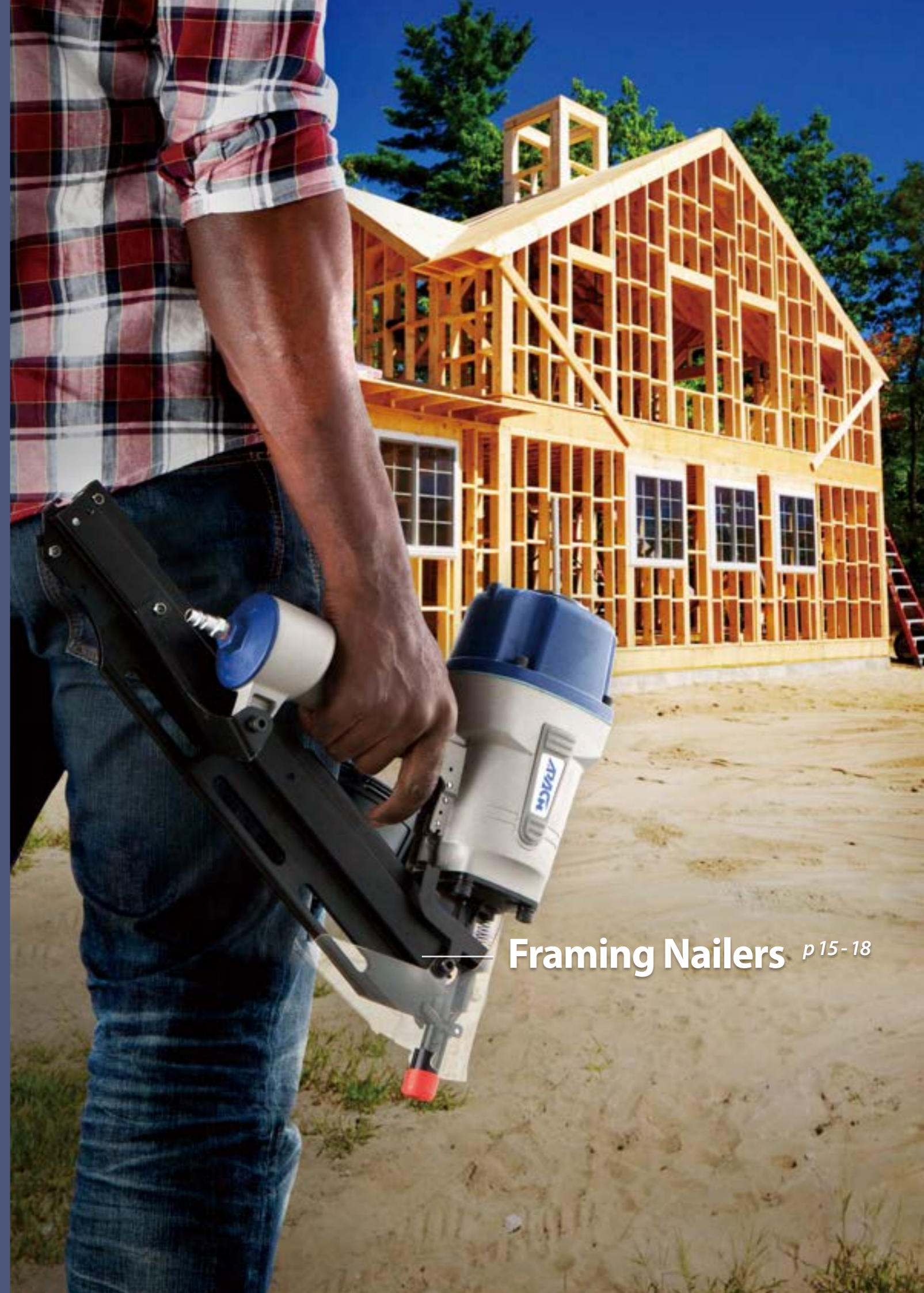
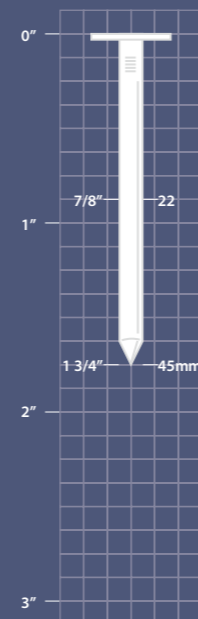

Framing Nailers p 15-18

# Framing Nailers

21 Degree Strip Framing Nailer

**AN9021-1**



AN9021-1

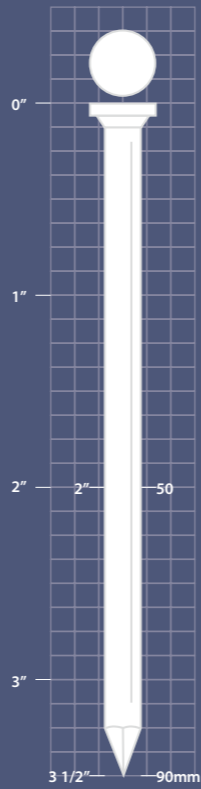

## Features

- Aggressive Toe-Nailing Teeth for slip-free Grip when Fastening
- Depth-of-Drive Adjustment
- Special Design No-Mar Rubber Pad
- Dedicated Sequential trigger or Bumper trigger or Anti-Double fire trigger for Enhanced safety and Durability
- Optional Hanger

## Fasteners

- 21° Full Head Plastic Collated Strip Nails
- Ø.113 - .149" / 2.87 - 3.8mm

## Applications



## Tool Specifications

Weight	Dimensions (LxWxH)	Operating Pressure	Load Capacity
3.7 kgs	442 x 124 x 331mm	5 - 7 kg / cm <sup>2</sup>	60 nails
8 lbs	17.4 x 4.88 x 13.03"	70 - 100 psi	60 nails

# Framing Nailers

34 Degree Strip Framing Nailer

**AN9034-1**



## Features

- Aggressive Toe-Nailing Teeth for slip-free Grip when Fastening
- Depth-of-Drive Adjustment
- Special Design No-Mar Rubber Pad
- Dedicated Sequential trigger or Bumper trigger or Anti-Double fire trigger for Enhanced safety and Durability
- Optional Hanger

## Fasteners

- 34° D Head Paper Tape Collated Strip Nails
- Ø.113 - .161" / 2.87 - 4.1mm

## Applications



## Tool Specifications

Weight	Dimensions (LxWxH)	Operating Pressure	Load Capacity
3.5 kgs	450 x 150 x 350mm	5 - 7 kg / cm <sup>2</sup>	75 nails
7.72 lbs	17.72 x 5.9 x 13.78"	70 - 100 psi	75 nails

AN9034-1

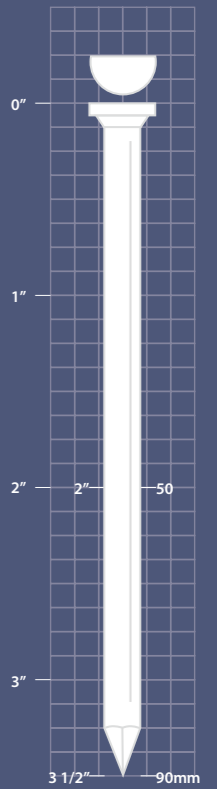

# Framing Nailers

34 Degree Strip Framing Nailer

**AN-10034-1**



## Features

- Depth-of-Drive Adjustment
- Aggressive Toe-Nailing Teeth for slip-free Grip when Fastening
- Special Design No-Mar Rubber Pad for better working performance
- Dedicated Sequential or Bump Fire Trigger for Enhanced Safety and Durability
- Light Weight and Well Balance
- Optional Hanger

## Fasteners

- 34° Round/D Head Paper Tape Collated Strip Nails
- Ø.113 - .161" / 2.87 - 4.1mm

## Applications



## Tool Specifications

Weight	Dimensions (LxWxH)	Operating Pressure	Load Capacity
3.43 kgs	354 x 153 x 443mm	5 - 7 kg / cm <sup>2</sup>	75 nails
7.5 lbs	14.2 x 6.1 x 17.7"	70 - 100 psi	75 nails

AN-10034-1

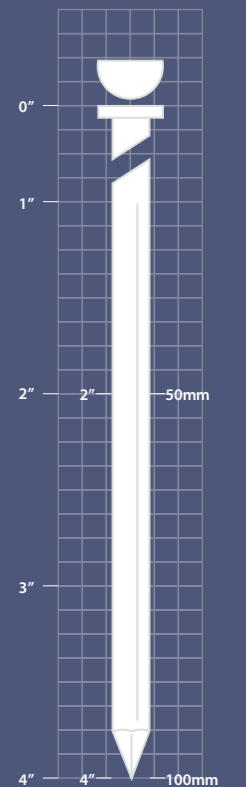

## Framing Nailers

21 Degree Strip Nailer

### AN-13021E



#### Features

- 360° Adjustable Exhaust Deflector with Noise Reducer
- Depth-of-Drive Adjustable
- Aggressive Toe-Nailing Teeth for Slip-Free Grip when Fastening
- Soft Rubber Grip for Added Comfort and Less Fatigue
- Well Balanced
- Sequential Fire Trigger
- Dry-Fire Lock

#### Fasteners

- 21° Full Head Plastic Collated Strip Nails
- Ø.131 - .165" / 3.33 - 4.19mm

#### Applications



#### Tool Specifications

Weight	Dimensions (LxWxH)	Operating Pressure	Load Capacity
5.4 kgs	452 x 188 x 588mm	6 - 8 kg / cm <sup>2</sup>	50 nails
11.88 lbs	17.8 x 7.4 x 23.1"	85 - 120 psi	50 nails

AN-13021E

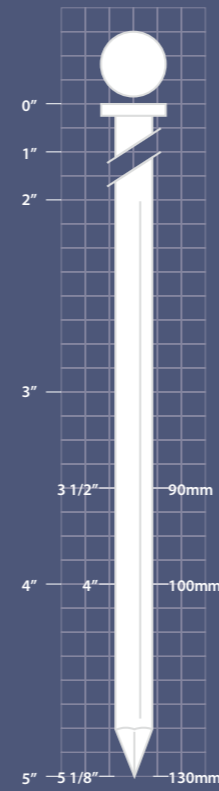

## Framing Nailers

21 Degree Strip Nailer

### AN-16021E



#### Features

- Front Exhaust Top Cap
- Depth-of-Drive Adjustable
- Well Balanced
- Sequential Fire Trigger

#### Fasteners

- 21° Full Head Plastic Collated Strip Nails
- Ø.149 - .181" / 3.8 - 4.6mm

#### Applications



#### Tool Specifications

Weight	Dimensions (LxWxH)	Operating Pressure	Load Capacity
7.0 kgs	532 x 150 x 557mm	6 - 8 kg / cm <sup>2</sup>	56 nails
15.4 lbs	20.9 x 5.9 x 21.9"	85 - 120 psi	56 nails

AN-16021E

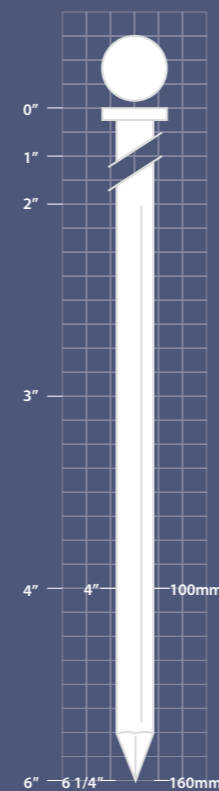

Finish Nailers p 19-27

# Micro Pinner

23 GA Micro Pinner



## PT-630

### Features

- Patented Adjustment-Free side loading magazine
- Double trigger
- Accepts both headless and mini head pins

### Fasteners

- 23 GA Headless and Mini Head Pins
- Length 12-30mm / 1/2- 1 3/16"
- Shank Diameter:0.64mm/.025"

### Applications



### Tool Specifications

Weight	Dimensions (LxWxH)	Operating Pressure	Load Capacity
1.2 kgs	196 x 42 x 182mm	5 - 7 kg / cm <sup>2</sup>	100 nails
2.64 lbs	7.7 x 1.6 x 7.2"	70 - 100 psi	100 nails

## PT-630

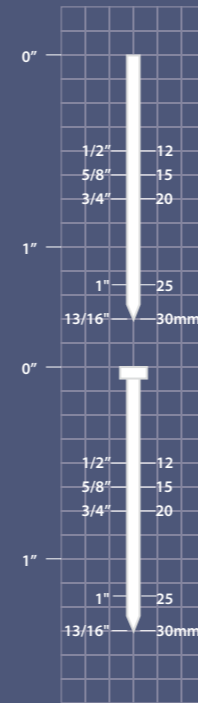

# Brad Nailers

21 GA Mini Brad Nailer



## LMF-40LAC

### Features

- 360° Adjustable Air Deflector
- No-Mar Rubber Pad Available
- Long Slim Nose for Precision Trimming

### Fasteners

- 21 Gauge Mini Brads
- Ø .033" / 0.84mm

### Applications



### Tool Specifications

Weight	Dimensions (LxWxH)	Operating Pressure	Load Capacity
1.30 kgs	231 x 58 x 218mm	5 - 7 kg / cm <sup>2</sup>	100 nails
2.86 lbs	9.1 x 2.3 x 8.6"	70 - 100 psi	100 nails

## LMF-40LAC

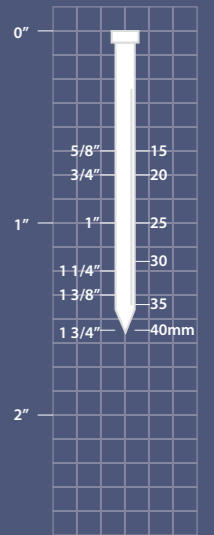

# Micro Pinner

23 GA Micro Pinner



## PT-635

### Features

- Extended Trigger for Rapid Applications
- Trigger Lock for Increased Safety
- Patented Adjustment - Free Side Loading Magazine
- Accepts Both Headless and Mini Head Pins
- Removable No-Mar Rubber Pad
- Durable Aluminum Magazine
- Rear Exhaust to Avoid Stains on Work Piece
- Full Wrap-Around Rubber Grip for Maximum Comfort
- Slim Tapered Nose for Precise Nail Placement

### Fasteners

- 23 GA Headless and Mini Head Pins
- Length: 12 - 35mm / 1/2-13/8"
- Shank Diameter: 0.64mm / .025"

### Applications



### Tool Specifications

Weight	Dimensions (LxWxH)	Operating Pressure	Load Capacity
0.96 kgs	205 x 43 x 174mm	5 - 7 kg / cm <sup>2</sup>	120 brads
2.1 lbs	8.07 x 1.69 x 6.85"	70 - 100 psi	120 brads

## PT-635

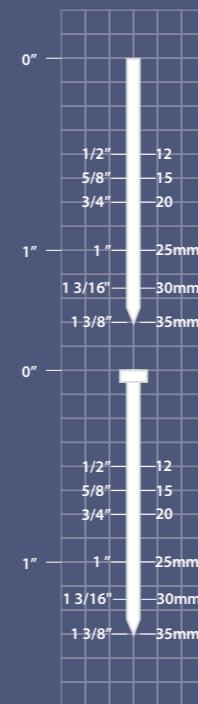

# Brad Nailers

18 GA Brad Nailer



## LNF-32AC

### Features

- 360° Adjustable Air Deflector
- Quick Release Nose Cover
- Optional Single-Bump Fire Switch Available
- No-Mar Rubber Pad Available (#22903801)

### Fasteners

- 18 Gauge Brads
- 0.050 x .040" / 1.25 x 1.0mm

### Applications



### Tool Specifications

Weight	Dimensions (LxWxH)	Operating Pressure	Load Capacity
1.17 kgs	243 x 58 x 204mm	5 - 7 kg / cm <sup>2</sup>	100 brads
2.57 lbs	9.6 x 2.3 x 8.0"	70 - 100 psi	100 brads

## LNF-32AC

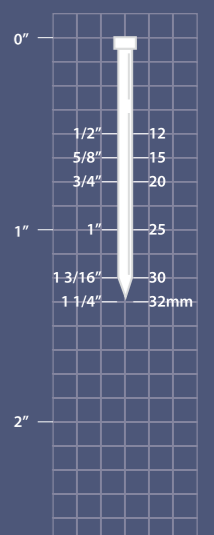

## Brad Nailers

18 GA Brad Nailer



### LNF-50AC

#### Features

- 360° Adjustable Air Deflector
- Quick Release Nose Cover
- Optional Single-Bump Fire Switch Available
- No-Mar Rubber Pad Available (#22903801)

#### Fasteners

- 18 Gauge Brads
- $\square$  .050 x .040" / 1.25 x 1.0mm

#### Applications



#### Tool Specifications

Weight	Dimensions (LxWxH)	Operating Pressure	Load Capacity
1.4 kgs	243 x 58 x 248mm	5 - 7 kg / cm <sup>2</sup>	100 nails
3.08 lbs	9.6 x 2.3 x 9.8"	70 - 100 psi	100 nails

### LNF-50AC

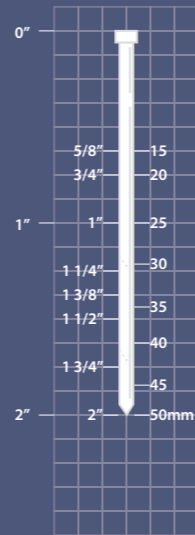

## Brad Nailers

2-in-1 Combination Tool



### LU-50FAC

#### Features

- 360° Adjustable Air Deflector
- Visual Reload Indicator
- Single-Bump Fire Switch
- Depth Adjustment
- No-Mar Tip
- Bottom Load

#### Fasteners

- 90 Series Staples & 18 Gauge Brads
- Staples Compatible with Atro 90, BeA 90, Duo-Fast 1800, Hitachi 11100, Haubold 6000, ISM 90, JK 781 & Senco L Series
- $\square$  .050 x .040" / 1.25 x 1.0mm

#### Applications



#### Tool Specifications

Weight	Dimensions (LxWxH)	Operating Pressure	Load Capacity
1.45 kgs	223 x 58 x 226mm	5 - 7 kg / cm <sup>2</sup>	100 Staples
3.19 lbs	8.8 x 2.3 x 10.3"	70 - 100 psi	100 Staples

### LU-50FAC

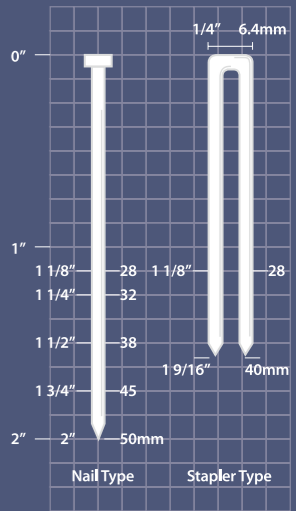

## Brad Nailers

18 GA Brad Nailer



### LNF-50AC-1

#### Features

- 360° Adjustable Air Deflector
- Quick Release Nose Cover
- Optional Single-Bump Fire Switch Available
- No-Mar Rubber Pad Available (#22903801)
- One Hand Operation

#### Fasteners

- 18 Gauge Brads
- $\square$  .050 x .040" / 1.25 x 1.0mm

#### Applications



#### Tool Specifications

Weight	Dimensions (LxWxH)	Operating Pressure	Load Capacity
1.4 kgs	243 x 58 x 248mm	5 - 7 kg / cm <sup>2</sup>	100 nails
3.08 lbs	9.6 x 2.3 x 9.8"	70 - 100 psi	100 nails

### LNF-50AC-1

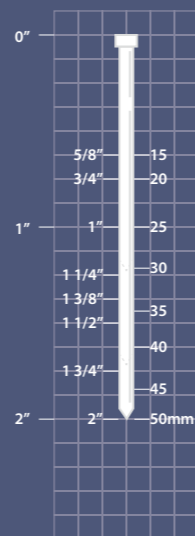

## Finish Nailers

15/16 GA Finish Nailer, Light Duty



### LT-50LAC

#### Features

- Accept Three Types of Fasteners without Any Adjustment
- 360° Rotatable Air Deflector
- Light and Compact, Ideal for Soft Wood Trimming and Fixation of Wood to Concrete
- Well Balanced with Comfortable Rubber Grip
- Removable No-Mar Rubber Pad (#22903801)

#### Fasteners

- 15 GA Finish Nails:  $\square$  .069" / 1.75mm
- 16 GA Finish Nails:  $\square$  .063 x .055" / 1.6 x 1.4mm
- 15 GA  $\emptyset$  1.83 Concrete Nails:  $\emptyset$  .072" / 1.83mm

#### Applications



#### Tool Specifications

Weight	Dimensions (LxWxH)	Operating Pressure	Load Capacity
1.4 kgs	250 x 58 x 250mm	5 - 7 kg / cm <sup>2</sup>	80 Nails
3.08 lbs	9.8 x 2.3 x 9.8"	70 - 100 psi	80 Nails

### LT-50LAC

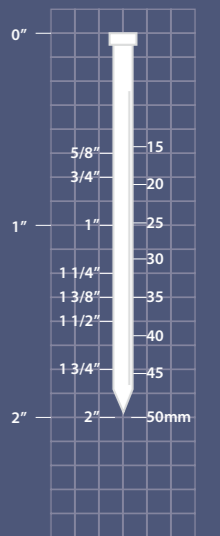

## Finish Nailers

15 / 16 GA Finish Nailer & Concrete Nailer, Light Duty



### LT-50LLAC

#### Features

- Accepts Both 16 GA Finish Nails & .072" (1.83 mm) Concrete Nails
- 360° Adjustable Air Deflector
- Light Weight
- Well Balanced
- Removable No-Mar Rubber Pad (#22903801)
- Long Magazine
- Holds 2 Strips of 16 GA Finish Nails

#### Fasteners

- 15 GA Finish Nails:  $\varnothing$ .069" / 1.75mm
- 16 GA Finish Nails:  $\varnothing$ .063 x .055" / 1.6 x 1.4mm
- 15 GA  $\varnothing$  1.83 Concrete Nails:  $\varnothing$ .072" / 1.83mm

#### Applications



#### Tool Specifications

Weight	Dimensions (LxWxH)	Operating Pressure	Load Capacity
1.4 kgs	250 x 58 x 250mm	5 - 7 kg / cm <sup>2</sup>	80 - 100 nails
3.08 lbs	9.8 x 2.3 x 9.8"	70 - 100 psi	80 - 100 nails

### LT-50LLAC

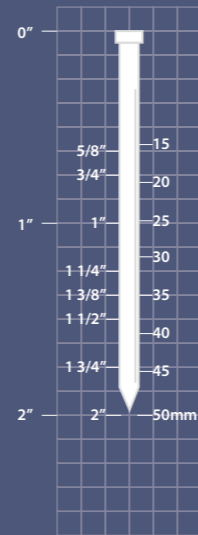

## Finish Nailers

15/16 GA Finish Nailer



### LT-1650AC

#### Features

- Accept 15/16GA Finish Nails
- 360° Adjustable Air Deflector
- Quick Release Nose Cover
- Well Balanced
- No-Mar Rubber Pad Available (#21903602)

#### Fasteners

- 15 GA Finish Nails:  $\varnothing$ .069" / 1.75mm
- 16 GA Finish Nails:  $\varnothing$ .063 x .055" / 1.6 x 1.4mm
- 15 GA  $\varnothing$  1.83 Concrete Nails:  $\varnothing$ .072" / 1.83mm

#### Applications



#### Tool Specifications

Weight	Dimensions (LxWxH)	Operating Pressure	Load Capacity
1.8 kgs	272 x 72 x 281mm	5 - 7 kg / cm <sup>2</sup>	100 nails
3.96 lbs	10.7 x 2.8 x 11.1"	70 - 100 psi	100 nails

### LT-1650AC

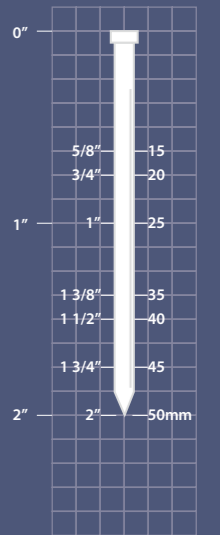

## Finish Nailers

15/16 GA Finish & Concrete Nailer, Heavy Duty



### LT-1650

#### Features

- Accept 15,16 GA Finish Nails &  $\varnothing$  1.83mm Concrete Pins
- 360° Adjustable Air Deflector
- Bolted Release Nose Cover
- Well Balanced - Powerful Motor
- No Mar Rubber Pad

#### Fasteners

- 15 GA Finish Nails:  $\varnothing$ .069" / 1.75mm
- 16 GA Finish Nails:  $\varnothing$ .063 x .055" / 1.6 x 1.4mm
- 15 GA  $\varnothing$  1.83 Concrete Nails:  $\varnothing$ .072" / 1.83mm

#### Applications



#### Tool Specifications

Weight	Dimensions (LxWxH)	Operating Pressure	Load Capacity
2.15 kgs	281 x 72 x 272mm	5 - 7 kg / cm <sup>2</sup>	100 nails
4.73 lbs	11.06 x 2.83 x 10.7"	70 - 100 psi	100 nails

### LT-1650

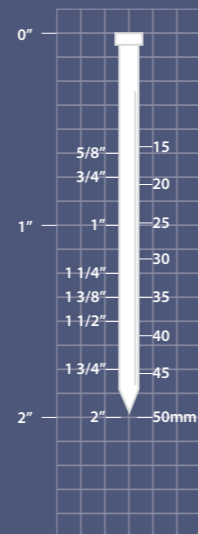

## Finish Nailers

15/16 GA Finish Nailer



### LT-1664AC

#### Features

- Accept 15/16GA Finish Nails
- 360° Adjustable Air Deflector
- Quick Release Nose Cover
- Well Balanced
- No-Mar Rubber Pad Available (#21903602)

#### Fasteners

- 15 GA Finish Nails:  $\varnothing$ .069" / 1.75mm
- 16 GA Finish Nails:  $\varnothing$ .063 x .055" / 1.6 x 1.4mm
- 15 GA  $\varnothing$  1.83 Concrete Nails:  $\varnothing$ .072" / 1.83mm

#### Applications



#### Tool Specifications

Weight	Dimensions (LxWxH)	Operating Pressure	Load Capacity
1.9 kgs	272 x 72 x 281mm	5 - 7 kg / cm <sup>2</sup>	100 nails
4.19 lbs	10.7 x 2.8 x 11.1"	70 - 100 psi	100 nails

### LT-1664AC

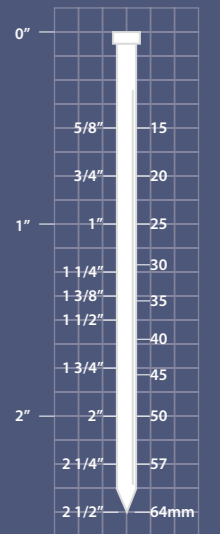

## Finish Nailers

16 GA Finish Nailer



### LT-1664EB

#### Features

- 360° Rotatable Air Deflector
- Rear Load, Durable Aluminum Magazine
- Tool-Free Quick Release Nose Cover for Easy Jam Removal
- Tool-Free Depth-of-Drive Adjustment
- Removable No-Mar Rubber Pad
- Dry-Fire Lock

#### Fasteners

- 16 GA Finish Nails
- Ø .063 x .055" / 1.6x1.4mm
- Length: 1 - 2 1/2" / 25 - 64mm

#### Applications



#### Tool Specifications

Weight	Dimensions (LxWxH)	Operating Pressure	Load Capacity
2.14 kgs	360 x 85 x 310mm	5 - 7 kg / cm <sup>2</sup>	100 nails
4.7 lbs	14.2 x 3.3 x 12.2"	70 - 100 psi	100 nails

### LT-1664EB

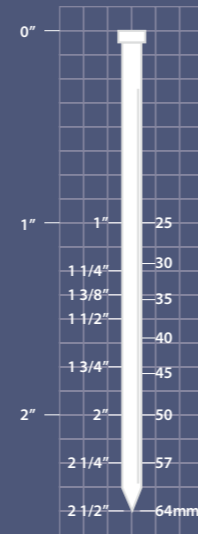

## Concrete Nailer

14 GA Concrete Nailer, Light Duty



### LHT-38

#### Features

- Accept Both .086 & .098" / 2.2 & 2.5 mm Concrete Nails
- 360° Adjustable Air Deflector
- Powerful
- Well Balanced

#### Fasteners

- Concrete Nails
- Shank Diameter: .086 & .098" / 2.2 & 2.5 mm

#### Applications



#### Tool Specifications

Weight	Dimensions (LxWxH)	Operating Pressure	Load Capacity
2.0 kgs	299 x 81 x 288mm	5 - 7 kg / cm <sup>2</sup>	80 nails
4.4 lbs	11.7 x 3.2 x 11.3"	70 - 100 psi	80 nails

### LHT-38

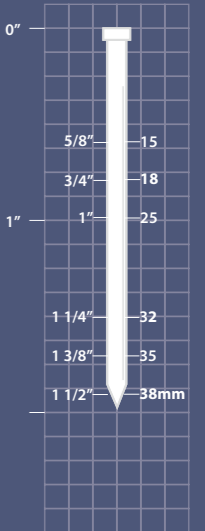

## Finish Nailers

DA Series Angle Finish Nailer



### DA-64E1

#### Features

- 360° Rotatable Air Deflector
- Rear Load, Durable Aluminum Magazine
- Tool-Free Quick Release Nose Cover for Easy Jam Removal
- Tool-Free Depth-of-Drive Adjustment
- Removable No-Mar Rubber Pad
- In-Line Magazine

#### Fasteners

- 15 Gauge Angle Finish Nails
- Compatible with Senco DA Series
- Ø .069" / 1.7mm

#### Applications

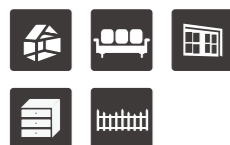

#### Tool Specifications

Weight	Dimensions (LxWxH)	Operating Pressure	Load Capacity
2.14 kgs	331 x 104 x 326mm	5 - 7 kg / cm <sup>2</sup>	100 nails
4.7 lbs	13.03 x 4.09 x 12.83"	70 - 100 psi	100 nails

### DA-64E1



## Concrete Nailer

14 GA Concrete Nailer, Heavy Duty



### LHT-64

#### Features

- Accept Both Ø .086 & .098" / 2.2 & 2.5mm Concrete Nails
- 360° Adjustable Air Deflector
- Powerful
- Well Balanced
- Quick Release Bolted Nose
- Sequential Trigger Mode, Can be Adjusted to Bump Fire Mode without Changing Parts.

#### Fasteners

- Concrete Nails
- Ø .086 & .098" / 2.2 & 2.5mm

#### Applications



#### Tool Specifications

Weight	Dimensions (LxWxH)	Operating Pressure	Load Capacity
2.7 kgs	282 x 94 x 306mm	5 - 7 kg / cm <sup>2</sup>	80 nails
5.94 lbs	11.1 x 3.7 x 12.5"	70 - 100 psi	80 nails

### LHT-64

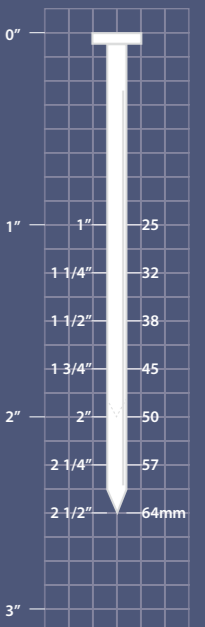



p28 - 58

# Staplers

## Staplers

SJK Series Fine Wire Stapler

### LU-SJK16F

LU-SJK16F

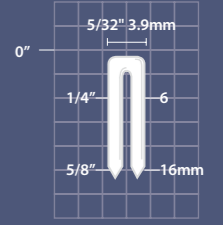

#### Features

- Hammer Cap
- Bottom Load, Jam Free Magazine
- Rear Exhaust to Avoid Oil Stains on Work Piece
- Slim Long Nose for Easy, Precise Staple Placement
- Extended Trigger for Rapid Stapling
- Double Trigger for Increased Safety
- Full Wrap-Around Rubber Grip

#### Fasteners

- SJK Series Staples
- Compatible with Omer SJK, Bostitch SJ3020, Senco TK Series
- $\square$  .030 x .023" / 0.76 x 0.58mm

#### Applications



#### Tool Specifications

Weight	Dimensions (LxWxH)	Operating Pressure	Load Capacity
0.88 kgs	219 x 43 x 144mm	4 - 7 kg / cm <sup>2</sup>	167 staples
1.95 lbs	8.6 x 1.7 x 5.7"	60 - 100 psi	167 staples

# Staplers

71 Series Fine Wire Stapler



## LU-7116F

### Features

- Hammer Cap
- Bottom Load, Jam Free Magazine
- Rear Exhaust to Avoid Oil Stains on Work Piece
- Slim Long Nose for Easy, Precise Staple Placement
- Extended Trigger for Rapid Stapling
- Double Trigger for Increased Safety
- Full Wrap-Around Rubber Grip

### Fasteners

- 71 Series Staples
- Compatible with Complete 71, Atro 7, BeA 71, JK 670, Haubold 7100, Senco C Series
- $\square$ .030 x .024" / 0.75 x 0.61mm

### Applications



### Tool Specifications

Weight	Dimensions (LxWxH)	Operating Pressure	Load Capacity
0.88 kgs	219 x 43 x 144mm	4 - 7 kg / cm <sup>2</sup>	178 staples
1.95 lbs	8.6 x 1.7 x 5.7"	60 - 100 psi	178 staples

## LU-7116F

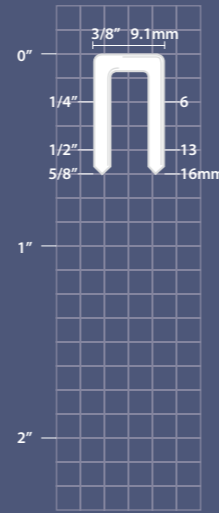

# Staplers

71 Series Fine Wire Stapler, Long Nose



## LU-7116LAC

### Features

- Hammer Cap
- Bottom Load, Jam Free Magazine
- Rear Exhaust Cover
- Slim Long Nose for Easy Aiming

### Fasteners

- 71 Series Staples
- Compatible With Complete 71, Atro 7, BeA 71, Haubold 7100, JK 670, Senco C Series
- $\square$ .030 x .024" / 0.75 x 0.61mm

### Applications



### Tool Specifications

Weight	Dimensions (LxWxH)	Operating Pressure	Load Capacity
1.1 kgs	220 x 43 x 215mm	5 - 7 kg / cm <sup>2</sup>	100 staples
2.4 lbs	8.7 x 1.7 x 8.5"	70 - 100 psi	100 staples

## LU-7116LAC

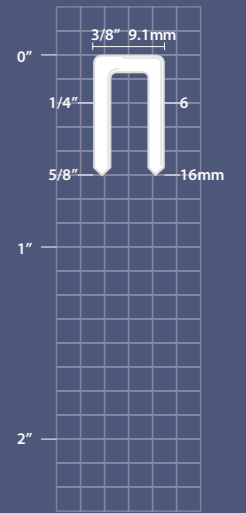

# Staplers

71 Series Fine Wire Stapler



## LU-7116AC

### Features

- Hammer Cap
- Bottom Load, Jam Free Magazine
- Rear Exhaust to Avoid Oil Stains on Work Piece
- Slim Long Nose for Easy, Precise Staple Placement
- Double Trigger for Increased Safety
- Comfortable Rubber Grip

### Fasteners

- 71 Series Staples
- Compatible with Complete 71, Atro 7, BeA 71, JK 670, Haubold 7100, Senco C Series
- $\square$ .030 x .024" / 0.75 x 0.61mm

### Applications



### Tool Specifications

Weight	Dimensions (LxWxH)	Operating Pressure	Load Capacity
1.0 kgs	220 x 43 x 163mm	5 - 7 kg / cm <sup>2</sup>	100 staples
2.2 lbs	8.7 x 1.7 x 6.4"	70 - 100 psi	100 staples

## LU-7116AC

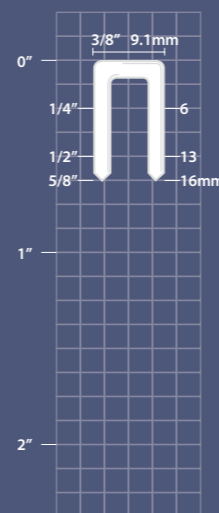

# Staplers

71 Series Auto-Fire Stapler



## LU-7116.1AUTO

### Features

- New & Improved
- Speed Adjustable. Minimum 27 Staples/Sec when Adjusted to Highest Speed.
- Light Squeeze Trigger to Single Fire, Full Squeeze to Auto-Fire No Adjustment Needed
- Hammer Cap
- Rear Exhaust
- Bottom Load Long Magazine – Quick Load and Easy Jam Clearance
- Low Fastener Re-Load Indicator Window

### Fasteners

- 71 Series
- Compatible With Complete 71, Atro 7, BeA 71, Haubold 7100, JK 670, Senco C Series
- $\square$ .030 x .024" / 0.75 x 0.61mm

### Applications



### Tool Specifications

Weight	Dimensions (LxWxH)	Operating Pressure	Load Capacity
1 kgs	220 x 45 x 148mm	6 - 7.7 kg / cm <sup>2</sup>	100 staples
2.2 lbs	8.7 x 1.8 x 5.8"	85 - 110 psi	100 staples

## LU-7116.1AUTO

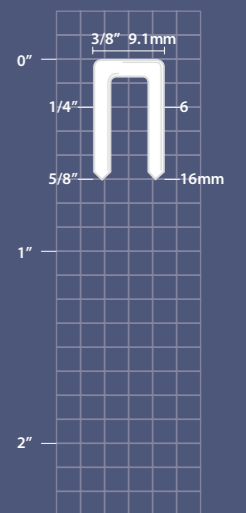

# Staplers

71 Series Auto-Fire Stapler, Long Magazine



## LU-7116.1AUTO/LM

### Features

- New & Improved
- Speed Adjustable. Minimum 27 Staples/Sec when Adjusted to Highest Speed.
- Light Squeeze Trigger to Single Fire, Full Squeeze to Auto-Fire No Adjustment Needed
- Hammer Cap
- Rear Exhaust
- Bottom Load Long Magazine – Quick Load and Easy Jam Clearance
- Low Fastener Re-Load Indicator Window

### Fasteners

- 71 Series Staples
- Compatible With Complete 71, Atro 7, BeA 71, Haubold 7100, JK 670, Senco C Series
- $\square$ .030 x .024" / 0.75 x 0.61mm

## LU-7116.1AUTO/LM

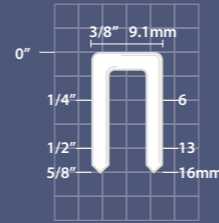

### Applications



### Tool Specifications

Weight	Dimensions (LxWxH)	Operating Pressure	Load Capacity
1.1 kgs	352 x 45 x 148mm	6 - 7.7 kg / cm <sup>2</sup>	358 staples
2.4 lbs	13.8 x 1.8 x 5.8"	85 - 110 psi	358 staples

# Staplers

14 Series Fine Wire Stapler



## LU-1416AC

### Features

- Hammer Cap
- Bottom Load, Jam Free Magazine
- Rear Exhaust Cover

### Fasteners

- 14 Series Compatible with Haubold 1400, JK KL1400, Fasco 14, Omer 68, Prebena VF, Spotnails 1400 Series
- $\square$ .030 x .024" / 0.75 x 0.61mm

## LU-1416AC

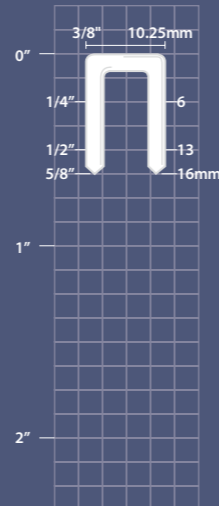

### Applications



### Tool Specifications

Weight	Dimensions (LxWxH)	Operating Pressure	Load Capacity
1.0 kgs	220 x 43 x 163mm	5 - 7 kg / cm <sup>2</sup>	100 staples
2.2 lbs	8.7 x 1.7 x 6.4"	70 - 100 psi	100 staples

# Staplers

23 Series Fine Wire Stapler



## LU-2316F

### Features

- Hammer Cap
- Bottom Load, Jam Free Magazine
- Rear Exhaust to Avoid Oil Stains on Work Piece
- Slim Long Nose for Easy, Precise Staple Placement
- Extended Trigger for Rapid Stapling
- Double Trigger for Increased Safety
- Full Wrap-Around Rubber Grip

### Fasteners

- 23 Series Staples
- Compatible with Omer 62, Senco B, Bostitch SB3020, Prebena M, Fasco SR3 Series
- $\square$ .030 x .020" / 0.75 x 0.50mm

### Applications



### Tool Specifications

Weight	Dimensions (LxWxH)	Operating Pressure	Load Capacity
0.88 kgs	219 x 43 x 144mm	4 - 7 kg / cm <sup>2</sup>	167 staples
1.95 lbs	8.6 x 1.7 x 5.7"	60 - 100 psi	167 staples

## LU-2316F

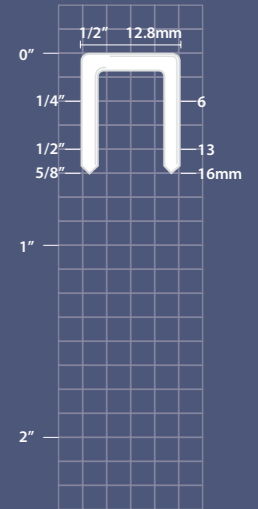

# Staplers

97 Series Fine Wire Stapler



## LU-9716F

### Features

- Hammer Cap
- Bottom Load, Jam Free Magazine
- Rear Exhaust to Avoid Oil Stains on Work Piece
- Slim Long Nose for Easy, Precise Staple Placement
- Extended Trigger for Rapid Stapling
- Double Trigger for Increased Safety
- Full Wrap-Around Rubber Grip

### Fasteners

- 97 Series Staples
- Compatible with Omer 4097, Haubold 4000, BeA 97, Senco W Series
- $\square$ .036 x .028" / 0.92 x 0.70mm

### Applications



### Tool Specifications

Weight	Dimensions (LxWxH)	Operating Pressure	Load Capacity
0.88 kgs	219 x 43 x 144mm	4 - 7 kg / cm <sup>2</sup>	125 staples
1.95 lbs	8.6 x 1.7 x 5.7"	60 - 100 psi	125 staples

## LU-9716F

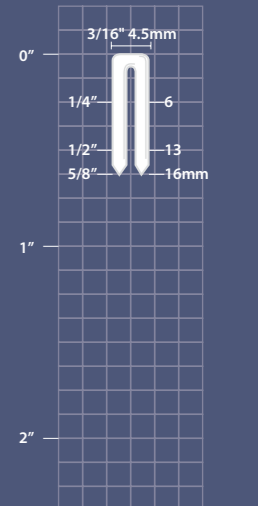

# Staplers

97 Series Fire Wire Stapler



## LU-9725AC

### Features

- 360° Rotatable Air Deflector
- Bottom Load, Durable Aluminum Magazine
- Comfortable Rubber Grip
- Bump Fire Trigger
- Sequential Trigger Valve Available
- Belt Hook Available

### Fasteners

- 97 Series Staples
- Compatible with Omer 4097, Haubold 4000, BeA 97, Senco W Series
- $\square$  .036 x .028" / 0.92 x 0.70mm

### Applications



### Tool Specifications

Weight	Dimensions (LxWxH)	Operating Pressure	Load Capacity
1.2 kgs	223 x 58 x 199mm	5 - 7 kg / cm <sup>2</sup>	100 staples
2.64 lbs	8.8 x 2.3 x 7.8"	70 - 100 psi	100 staples

## LU-9725AC

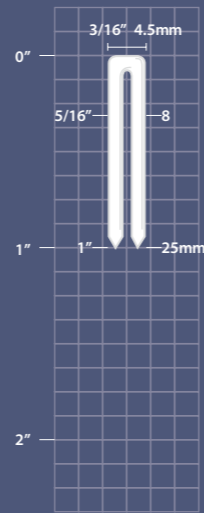

# Staplers

80 Series Fine Wire Stapler



## LU-8016F

### Features

- Hammer Cap
- Bottom Load, Jam Free Magazine
- Rear Exhaust to Avoid Oil Stains on Work Piece
- Slim Long Nose for Easy, Precise Staple Placement
- Extended Trigger for Rapid Stapling
- Double Trigger for Increased Safety
- Full Wrap-Around Rubber Grip

### Fasteners

- 80 Series Staples
- Compatible with Complete 80, Atro 8, BeA 80, JK 680, Haubold 800 Series
- $\square$  .036 x .028" / 0.91 x 0.71mm

### Applications



### Tool Specifications

Weight	Dimensions (LxWxH)	Operating Pressure	Load Capacity
0.88 kgs	219 x 43 x 144mm	4 - 7 kg / cm <sup>2</sup>	140 staples
1.95 lbs	8.6 x 1.7 x 5.7"	60 - 100 psi	140 staples

## LU-8016F

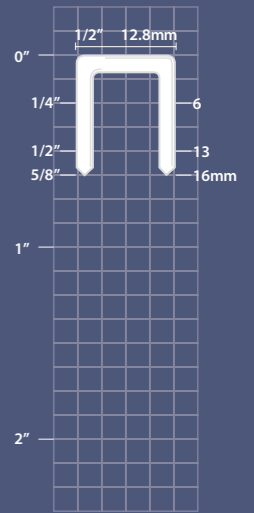

# Staplers

84 Series Fine Wire Stapler



## LU-8416AC

### Features

- Hammer Cap
- Bottom Load, Jam Free Magazine
- Rear Exhaust to Avoid Oil Stains on Work Piece
- Slim Long Nose for Easy, Precise Staple Placement
- Double Trigger for Increased Safety
- Comfortable Rubber Grip

### Fasteners

- 84 Series Staples
- Compatible with Atro 84, Bostitch 84, BeA SBNK, Prebena AD
- $\square$  .038 x .026" / 0.95 x 0.65mm

### Applications



### Tool Specifications

Weight	Dimensions (LxWxH)	Operating Pressure	Load Capacity
1.0 kgs	220 x 43 x 163mm	5 - 7 kg / cm <sup>2</sup>	100 staples
2.2 lbs	8.7 x 1.7 x 6.4"	70 - 100 psi	100 staples

## LU-8416AC

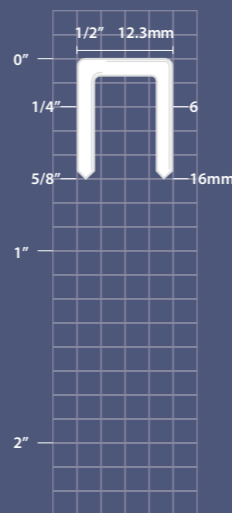

# Staplers

80 Series Fine Wire Stapler



## LU-8016AC.1

### Features

- Hammer Cap
- Bottom Load, Jam Free Magazine
- Rear Exhaust to Avoid Oil Stains on Work Piece
- Slim Long Nose for Easy, Precise Staple Placement
- Double Trigger for Increased Safety
- Comfortable Rubber Grip

### Fasteners

- 80 Series Staples
- Compatible with Complete 80, Atro 8, BeA 80, JK 680, Haubold 800 Series
- $\square$  .036 x .028" / 0.91 x 0.71mm

### Applications



### Tool Specifications

Weight	Dimensions (LxWxH)	Operating Pressure	Load Capacity
1.0 kgs	220 x 43 x 163mm	5 - 7 kg / cm <sup>2</sup>	100 staples
2.2 lbs	8.7 x 1.7 x 6.4"	70 - 100 psi	100 staples

## LU-8016AC.1

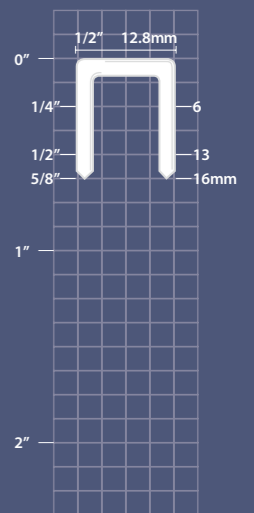

# Staplers

80 Series Auto-Fire Stapler



## LU-8016.1AUTO

### Features

- New & Improved
- Speed Adjustable. Minimum 27 Staples / Sec when Adjusted to Highest Speed
- Light Squeeze Trigger to Single Fire, Full Squeeze to Auto-Fire No Adjustment Needed
- Hammer Cap
- Rear Exhaust
- Bottom Load Magazine – Quick Load & Easy Jam Clearance

### Fasteners

- 80 Series Staples
- Compatible with Complete 80, Atro 8, BeA 80, JK680, Haubold 800 Series
- $\square$ .036 x .028" / 0.91 x 0.71mm

### Applications



### Tool Specifications

Weight	Dimensions (LxWxH)	Operating Pressure	Load Capacity
1 kgs	220 x 45 x 148mm	6 - 7.7 kg / cm <sup>2</sup>	100 staples
2.2 lbs	8.7 x 1.8 x 5.8"	85 - 110 psi	100 staples

## LU-8016.1AUTO

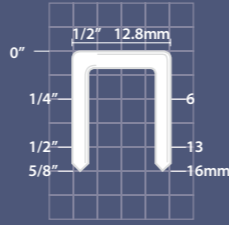

# Staplers

80 Series Fine Wire Stapler



## LU-8025AC

### Features

- 360° Rotatable Air Deflector
- Bottom Load, Durable Aluminum Magazine
- Comfortable Rubber Grip
- Bump Fire Trigger
- Sequential Trigger Valve Available
- Belt Hook Available

### Fasteners

- 80 Series Staples
- Compatible with Complete 80, Atro 8, BeA 80, JK 680, Haubold 800 Series
- $\square$ .036 x .028" / 0.91 x 0.71mm

### Applications



### Tool Specifications

Weight	Dimensions (LxWxH)	Operating Pressure	Load Capacity
1.2 kgs	223 x 58 x 199mm	5 - 7 kg / cm <sup>2</sup>	100 staples
2.64 lbs	8.8 x 2.3 x 7.8"	70 - 100 psi	100 staples

## LU-8025AC

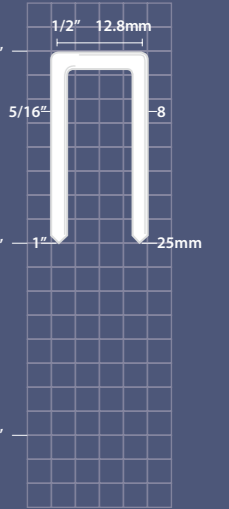

# Staplers

80 Series Auto-Fire Stapler, Long Magazine



## LU-8016.1AUTO/LM

### Features

- New & Improved
- Speed Adjustable. Minimum 27 Staples / Sec when Adjusted to Highest Speed
- Light Squeeze Trigger to Single Fire, Full Squeeze to Auto-Fire No Adjustment Needed
- Hammer Cap
- Rear Exhaust
- Bottom Load Long Magazine – Quick Load and Easy Jam Clearance
- Low Fastener Re-Load Indicator Window

### Fasteners

- 80 Series Staples
- Compatible with Complete 80, Atro 8, BeA 80, JK 680, Haubold 800 Series
- $\square$ .036 x .028" / 0.91 x 0.71mm

### Applications



### Tool Specifications

Weight	Dimensions (LxWxH)	Operating Pressure	Load Capacity
1.1 kgs	352 x 45 x 148mm	6 - 7.7 kg / cm <sup>2</sup>	290 staples
2.4 lbs	13.8 x 1.8 x 5.8"	85 - 110 psi	290 staples

## LU-8016.1AUTO/LM

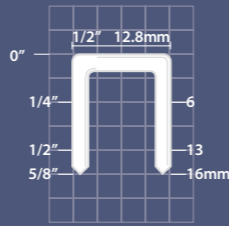

# Staplers

4J Series Stapler



## LU-425JAC

### Features

- 360° Rotatable Air Deflector
- Bottom Load, Durable Aluminum Magazine
- Comfortable Rubber Grip
- Bump Fire Trigger
- Sequential Trigger Valve Available
- Belt Hook Available

### Fasteners

- 20 Gauge Staples
- Compatible with Max 4J Series
- $\square$ .047 x .024" / 1.2 x 0.6mm

### Applications



### Tool Specifications

Weight	Dimensions (LxWxH)	Operating Pressure	Load Capacity
1.2 kgs	223 x 58 x 199mm	5 - 7 kg / cm <sup>2</sup>	100 staples
2.64 lbs	8.8 x 2.3 x 7.8"	70 - 100 psi	100 staples

## LU-425JAC

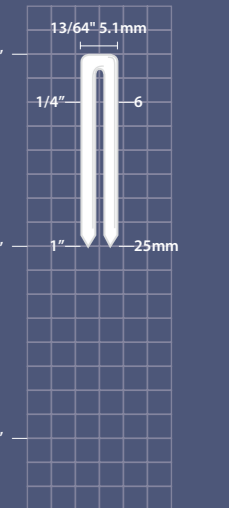

# Staplers

MAX 10F Series Fine Wire Staper

## LU-1016F



### Features

- Hammer Cap
- Bottom Load, Jam Free Magazine
- Rear Exhaust to Avoid Oil Stains on Work Piece
- Slim Long Nose for Easy, Precise Staple Placement
- Extended Trigger for Rapid Stapling
- Double Trigger for the Increased Safety
- Full Wrap-Around Rubber Grip

### Fasteners

- 22 Gauge Staples
- Compatible with MAX 10F
- .029 x .020" / 0.75 x 0.52mm

### Applications



### Tool Specifications

Weight	Dimensions (LxWxH)	Operating Pressure	Load Capacity
1.0 kgs	220 x 43 x 163mm	5 - 7 kg / cm <sup>2</sup>	100 staples
2.2 lbs	8.7 x 1.7 x 6.4"	70 - 100 psi	100 staples

## LU-1016F

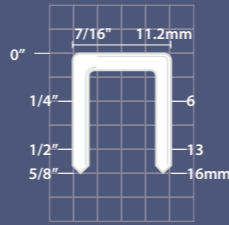

# Staplers

MAX 10J Series Auto-Fire Staplers

## LU-1016AUTO



### Features

- New & Improved
- Speed Adjustable Minimum 27 Staples/ Sec when djusted to Highest Speed.
- Light Squeeze Trigger to Single Fire, Full Squeeze to Auto-Fire No Adjustment Needed.
- Hammer Cap
- Rear Exhaust
- Bottom Load, Jam Free Magazine
- Comfortable Rubber Grip

### Fasteners

- 20 Gauge Staples - Compatible with Max 10J
- Ø.047 x .024" / 1.20 x 0.60mm

### Applications



### Tool Specifications

Weight	Dimensions (LxWxH)	Operating Pressure	Load Capacity
1.0 kgs	220 x 43 x 163mm	5 - 7 kg / cm <sup>2</sup>	100 staples
2.2 lbs	8.7 x 1.7 x 6.4"	70 - 100 psi	100 staples

## LU-1016AUTO

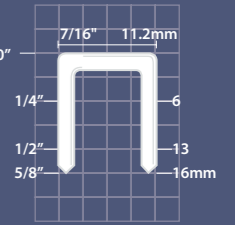

# Staplers

MAX 10J Series Fine Wire Staper

## LU-1016J



### Features

- Hammer Cap
- Bottom Load, Jam Free Magazine
- Rear Exhaust to Avoid Oil Stains on Work Piece
- Slim Long Nose for Easy, Precise Staple Placement
- Extended Trigger for Rapid Stapling
- Double Trigger for the Increased Safety
- Full Wrap-Around Rubber Grip

### Fasteners

- 20 Gauge Staples
- Compatible with MAX 10J
- .047 x .024" / 1.20 x 0.60mm

### Applications



### Tool Specifications

Weight	Dimensions (LxWxH)	Operating Pressure	Load Capacity
1.0 kgs	220 x 43 x 163mm	5 - 7 kg / cm <sup>2</sup>	100 staples
2.2 lbs	8.7 x 1.7 x 6.4"	70 - 100 psi	100 staples

## LU-1016J

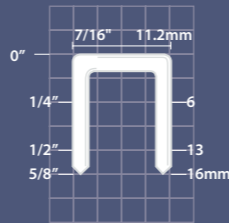

# Staplers

10J Series Stapler

## LU-1025JAC



### Features

- 360° Rotatable Air Deflector
- Bottom Load, Durable Aluminum Magazine
- Comfortable Rubber Grip
- Bump Fire Trigger
- Sequential Trigger Valve Available
- Belt Hook Available

### Fasteners

- 20 Gauge Staples
- Compatible with Max 10J Series
- □.047 x .024" / 1.2 x 0.6mm

### Applications



### Tool Specifications

Weight	Dimensions (LxWxH)	Operating Pressure	Load Capacity
1.2 kgs	223 x 58 x 199mm	5 - 7 kg / cm <sup>2</sup>	100 staples
2.64 lbs	8.8 x 2.3 x 7.8"	70 - 100 psi	100 staples

## LU-1025JAC

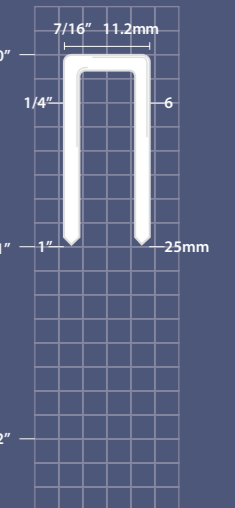

# Staplers

50 Series Fine Wire Stapler



## LU-5018AC

### Features

- Hammer Cap
- Bottom Load, Jam Free Magazine
- Rear Exhaust to Avoid Oil Stains on Work Piece
- Slim Long Nose for Easy, Precise Staple Placement
- Double Trigger for Increased Safety
- Comfortable Rubber Grip

### Fasteners

- 50 Series Staples
- Compatible with Complete 50, Duo-Fast 50, BeA 95, Omer 50, Prebena D
- $\square$ .050 x .020" / 1.27 x 0.50mm

### Applications



### Tool Specifications

Weight	Dimensions (LxWxH)	Operating Pressure	Load Capacity
1.0 kgs	220 x 43 x 163mm	5 - 7 kg / cm <sup>2</sup>	100 staples
2.2 lbs	8.7 x 1.7 x 6.4"	70 - 100 psi	100 staples

## LU-5018AC

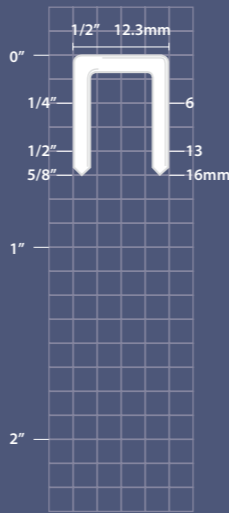

# Staplers

18 GA Narrow Crown Stapler



## LU-9025AC

### Features

- 360° Rotatable Air Deflector
- Bottom Load, Durable Aluminum Magazine
- Comfortable Rubber Grip
- Bump Fire Trigger
- Sequential Trigger Valve Available
- Belt Hook Available

### Fasteners

- 90 Series Staples
- Compatible with Complete L, BeA 90, Duo-Fast 1800, Senco L Series
- $\square$ .050 x .040" / 1.25 x 1.00 mm

### Applications



### Tool Specifications

Weight	Dimensions (LxWxH)	Operating Pressure	Load Capacity
1.2 kgs	223 x 58 x 199 mm	5 - 7 kg / cm <sup>2</sup>	100 staples
2.64 lbs	8.8 x 2.3 x 7.8"	70 - 100 psi	100 staples

## LU-9025AC

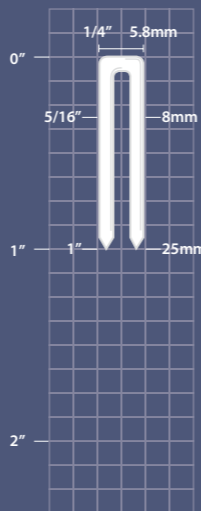

# Staplers

18 GA Narrow Crown Stapler



## LU-9032AC

### Features

- 360° Rotatable Air Deflector
- Bottom Load, Durable Aluminum Magazine
- Comfortable Rubber Grip
- Bump Fire Trigger
- Sequential Trigger Valve Available
- Belt Hook Available

### Fasteners

- 90 series staples
- Compatible with Atro 90, BeA 90, Duo-Fast 1800, Hitachi 11100, Haubold 6000, ISM 90, JK 781 & Senco L Series
- $\square$ .050 x .040" / 1.25 x 1.0mm

### Applications



### Tool Specifications

Weight	Dimensions (LxWxH)	Operating Pressure	Load Capacity
1.30 kgs	223 x 58 x 213mm	5 - 7 kg / cm <sup>2</sup>	100 staples
2.86 lbs	8.8 x 2.3 x 8.4"	70 - 100 psi	100 staples

## LU-9032AC

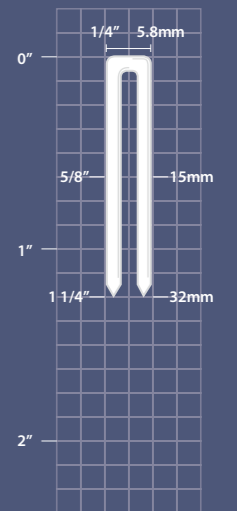

# Staplers

18 GA Narrow Crown Stapler, Light Duty



## LU-9040LAC

### Features

- 360° Adjustable Air Deflector
- Bottom Load
- Light Weight
- Well Balanced

### Fasteners

- 90 Series Staples
- Compatible with Atro 90, BeA 90, Duo-Fast 1800, Hitachi 11100, Haubold 6000, ISM 90, JK 781 & Senco L Series
- $\square$ .050 x .040" / 1.25 x 1.0mm

### Applications



### Tool Specifications

Weight	Dimensions (LxWxH)	Operating Pressure	Load Capacity
1.38 kgs	223 x 58 x 246mm	5 - 7 kg / cm <sup>2</sup>	100 staples
3.03 lbs	8.8 x 2.3 x 9.7"	70 - 100 psi	100 staples

## LU-9040LAC

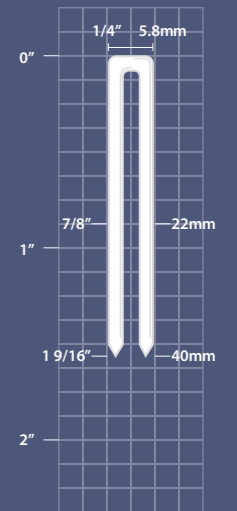

# Staplers

18 GA Narrow Crown Stapler, Light Duty



## LU-9040LAD

### Features

- 360° Adjustable Air Deflector
- Bottom Load
- Light Weight
- Well Balanced
- Tool-Free Depth Adjustment

### Fasteners

- Compatible with 90 Series : Complete L, BeA 90, Duo-Fast 1800, Senco L Series
- $\square$  .050 x .040" / 1.25 x 1.0mm

### Applications



### Tool Specifications

Weight	Dimensions (LxWxH)	Operating Pressure	Load Capacity
1.38 kgs	223 x 58 x 246mm	5 - 7 kg / cm <sup>2</sup>	100 staples
3.03 lbs	8.8 x 2.3 x 9.7"	70 - 100 psi	100 staples

## LU-9040LAD

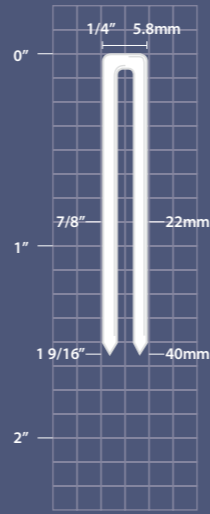

# Staplers

18 GA Narrow Crown Stapler, Heavy Duty



## LU-9040KT

### Features

- 360° Adjustable Exhaust
- Top Load Long Magazine for Increased Efficiency, Quick and Easy Re-loading
- Well Balanced and Light Weight
- Powerful Motor with Minimum Recoil for Enhanced Comfort of Use and Productivity
- Tool-Free Quick Release Nose for Jam Removal in Seconds

### Fasteners

- 18 GA Narrow Crown 90 Series
- Compatible with Complete L, BeA 90, Duo-Fast 1800, Senco L Series
- $\square$  .050" x .040" / 1.25 x 1.0mm

### Applications



### Tool Specifications

Weight	Dimensions (LxWxH)	Operating Pressure	Load Capacity
1.2 kgs	303 x 72 x 256mm	5 - 7 kg / cm <sup>2</sup>	150 staples
2.64 lbs	11.92 x 2.83 x 10.07"	70 - 100 psi	150 staples

## LU-9040KT

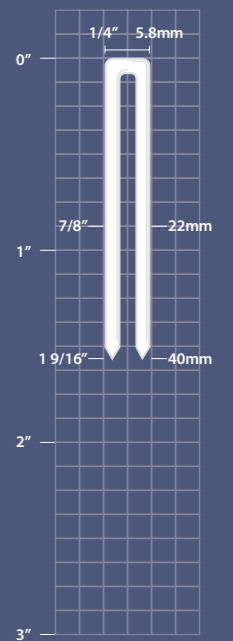

# Staplers

18 GA Narrow Crown Stapler, Heavy Duty



## LU-9040HAC

### Features

- Heavy Duty Version for Hardwood Applications
- 360° Rotatable Air Deflector
- Bottom Load, Durable Aluminum Magazine
- Comfortable Rubber Grip
- Bump Fire Trigger

### Fasteners

- 90 Series Staples
- Compatible with Atro 90, BeA 90, Duo-Fast 1800, Hitachi 11100, Haubold 6000, ISM 90, JK 781 & Senco L Series
- $\square$  .050 x .040" / 1.25 x 1.0mm

### Applications



### Tool Specifications

Weight	Dimensions (LxWxH)	Operating Pressure	Load Capacity
1.75 kgs	272 x 72 x 271mm	5 - 7 kg / cm <sup>2</sup>	100 staples
3.85 lbs	10.7 x 2.8 x 10.7"	70 - 100 psi	100 staples

## LU-9040HAC

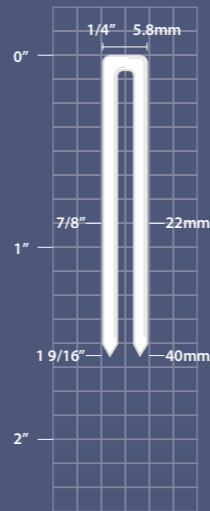

# Staplers

18 GA Medium Crown Stapler



## LU-9225AC

### Features

- 360° Rotatable Air Deflector
- Bottom Load, Durable Aluminum Magazine
- Comfortable Rubber Grip
- Bump Fire Trigger
- Sequential Trigger Valve Available
- Belt Hook Available

### Fasteners

- 92 Series Staples
- Compatible with Atro 92, BeA 92, Bostitch SL5035, JK 664, Nikema 92, Prebena H Series
- $\square$  .050 x .040" / 1.25 x 1.0mm

### Applications



### Tool Specifications

Weight	Dimensions (LxWxH)	Operating Pressure	Load Capacity
1.2 kgs	223 x 58 x 199mm	5 - 7 kg / cm <sup>2</sup>	100 staples
2.64 lbs	8.8 x 2.3 x 7.8"	70 - 100 psi	100 staples

## LU-9225AC

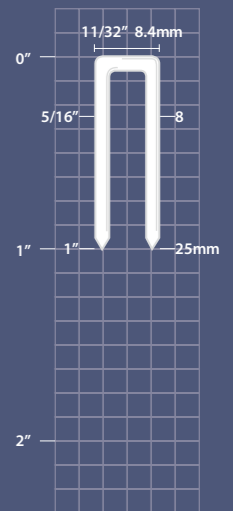

# Staplers

18 GA Medium Crown Stapler, Light Duty



## LU-9240LAC

### Features

- 360° Rotatable Air Deflector
- Bottom Load, Durable Aluminum Magazine
- Comfortable Rubber Grip
- Bump Fire Trigger
- Sequential Trigger Valve Available
- Belt Hook Available

### Fasteners

- 92 Series Staples
- Compatible with Atro 92, BeA 92, Bostitch SL5035, JK 664, Nikema 92, Prebena H Series
- $\square$ .050 x .040" / 1.25 x 1.0mm

### Applications



### Tool Specifications

Weight	Dimensions (LxWxH)	Operating Pressure	Load Capacity
1.38 kgs	223 x 58 x 246mm	5 - 7 kg / cm <sup>2</sup>	100 staples
3.03 lbs	8.8 x 2.3 x 9.7"	70 - 100 psi	100 staples

## LU-9240LAC

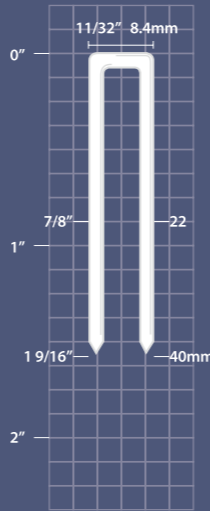

# Staplers

18 GA Medium Crown Stapler



## LU-G25AC

### Features

- 360° Rotatable Air Deflector
- Bottom Load, Durable Aluminum Magazine
- Comfortable Rubber Grip
- Bump Fire Trigger
- Sequential Trigger Valve Available
- Belt Hook Available

### Fasteners

- G Series
- Compatible with Complete M, Duo-Fast W18, JK 782, Omer SG44, Senco M, Prebena G Series
- $\square$ .050 x .040" / 1.25 x 1.00mm

### Applications



### Tool Specifications

Weight	Dimensions (LxWxH)	Operating Pressure	Load Capacity
1.2 kgs	223 x 58 x 199mm	5 - 7 kg / cm <sup>2</sup>	100 staples
2.64 lbs	8.8 x 2.3 x 7.8"	70 - 100 psi	100 staples

## LU-G25AC

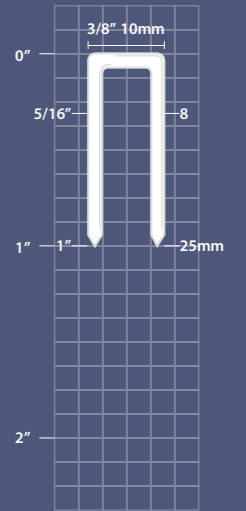

# Staplers

18 GA Medium Crown Stapler, Heavy Duty



## LU-9240HAC

### Features

- Heavy Duty Version for Hardwood Applications
- 360° Rotatable Air Deflector
- Bottom Load, Durable Aluminum Magazine
- Comfortable Rubber Grip
- Bump Fire Trigger

### Fasteners

- 92 Series Staples
- Compatible with Atro 92, BeA 92, Bostitch SL5035, JK 664, Nikema 92, Prebena H Series
- $\square$ .050 x .040" / 1.25 x 1.0mm

### Applications



### Tool Specifications

Weight	Dimensions (LxWxH)	Operating Pressure	Load Capacity
1.75 kgs	272 x 72 x 271mm	5 - 7 kg / cm <sup>2</sup>	100 staples
3.85 lbs	10.7 x 2.8 x 10.7"	70 - 100 psi	100 staples

## LU-9240HAC

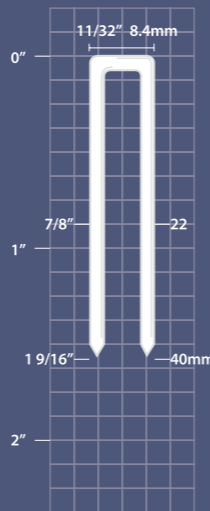

# Staplers

18 GA Medium Crown Stapler, Long Nose



## LU-G32HAC

### Features

- 360° Adjustable Air Deflector
- Bottom Load
- Light Weight
- Well Balanced
- With Vinyl Siding Guide
- Long Slim Nose

### Fasteners

- G Series
- Compatible with Complete M, Duo-Fast W18, JK 782, Omer SG44, Senco M, Prebena G Series
- $\square$ .050 x .040" / 1.25 x 1.0mm

### Applications



### Tool Specifications

Weight	Dimensions (LxWxH)	Operating Pressure	Load Capacity
1.35 kgs	223 x 58 x 236mm	5 - 7 kg / cm <sup>2</sup>	100 staples
2.97 lbs	8.8 x 2.3 x 9.3"	70 - 100 psi	100 staples

## LU-G32HAC

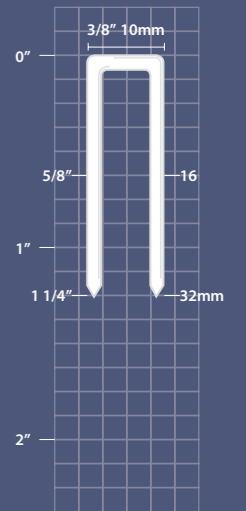

# Staplers

18 GA Medium Crown Stapler



## LU-G40LAC

### Features

- 360° Rotatable Air Deflector
- Bottom Load, Durable Aluminum Magazine
- Comfortable Rubber Grip
- Bump Fire Trigger
- Sequential Trigger Valve Available
- Belt Hook Available
- Vinyl Siding Yoke available (#18303101A)

### Fasteners

- G Series
- Compatible with Complete M, Duo-Fast W18, JK 782, Omer SG44, Senco M, Prebena G Series
- $\square$ .050 x .040" / 1.25 x 1.0mm

### Applications



### Tool Specifications

Weight	Dimensions (LxWxH)	Operating Pressure	Load Capacity
1.38 kgs	223 x 58 x 249mm	5 - 7 kg / cm <sup>2</sup>	100 staples
3 lbs	8.8 x 2.3 x 9.8"	70 - 100 psi	100 staples

## LU-G40LAC

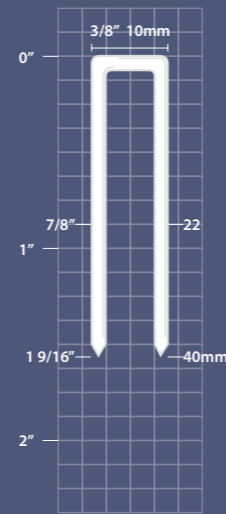

# Staplers

18 GA Wide Crown Stapler



## LU-50040LAC

### Features

- 360° Adjustable Air Deflector
- Bottom Load
- Light Weight
- Well Balanced
- Vinyl Siding Yoke Available (#18303101A)

### Fasteners

- 500 Series
- Compatible with Haubold 500 Series Staples
- $\square$ .050 x .040" / 1.25 x 1.0mm

### Applications



### Tool Specifications

Weight	Dimensions (LxWxH)	Operating Pressure	Load Capacity
1.38 kgs	223 x 58 x 249mm	5 - 7 kg / cm <sup>2</sup>	100 staples
3.03 lbs	8.8 x 2.3 x 9.8"	70 - 100 psi	100 staples

## LU-50040LAC

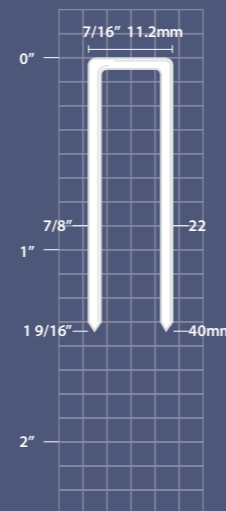

# Staplers

18 GA Wide Crown Stapler

## LU-9438AC



### Features

- 360° Rotatable Air Deflector
- Bottom Load, Durable Aluminum Magazine
- Comfortable Rubber Grip
- Bump Fire Trigger
- Sequential Trigger Valve Available
- Belt Hook Available

### Fasteners

- 94 series staples
- Compatible with Omer 94, Atro 94, BeA 94, Bostitch 94, Prebena HB Series
- $\square$ .050 x .040" / 1.25 x 1.0mm

### Applications

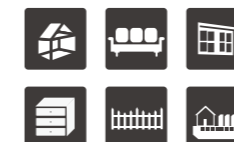

### Tool Specifications

Weight	Dimensions (LxWxH)	Operating Pressure	Load Capacity
1.38 kgs	223 x 58 x 249mm	5 - 7 kg / cm <sup>2</sup>	100 staples
3 lbs	8.8 x 2.3 x 9.8"	70 - 100 psi	100 staples

## LU-9438AC

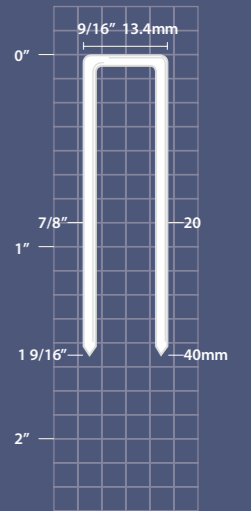

# Staplers

16 GA Medium Crown Stapler

## LU-851LC1



### LU-851LC1 / 16 GA

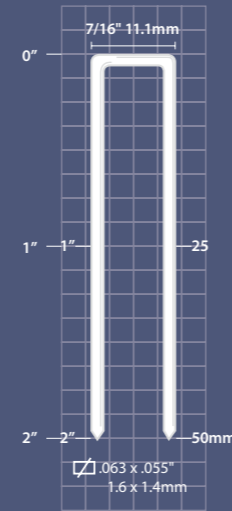

### LU-851LC1 / 17 GA

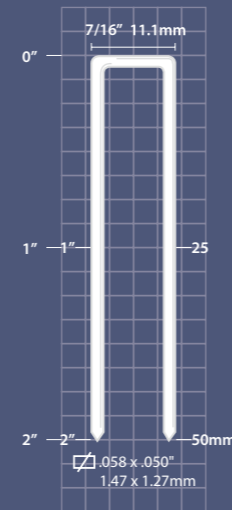

#### Features

- Lightweight and Well-Balanced to Reduce Fatigue and Increased Handling
- Tool-Free Depth of Drive Adjustment
- Robust Metal 360° Adjustable Exhaust
- Extended Two Finger Trigger
- Dedicated Bump Fire (Orange) or Full Sequential Trigger (Black) Available
- Tool-Free Quick-Release Nose for Jam Clearance
- Robust Light Engineered Polymer Magazine with Stainless Rail Top for Increased Durability
- Top Load Long Magazine - Quick Loading
- Open Magazine for Viewing Fastener Quantity
- Protected Pusher Spring
- Slim Long Nose for Easy Line of Sight & Easy Access to Tight Spots
- Increased Bumper Life = Less Downtime and Service Cost

#### Fasteners

- 16 GA - Compatible with Complete N, BeA 16(155), Senco N, Haubold KG 700, Duo-Fast 7600
- 17 GA - Compatible with Senco O Series

#### Applications



#### Tool Specifications

Weight	Dimensions (LxWxH)	Operating Pressure	Load Capacity
2.18 kgs	377 x 72 x 276mm	6 - 8 kg / cm <sup>2</sup>	140 staples
4.8 lbs	14 7/8 x 2 7/8 x 10 7/8"	70 - 110 psi	140 staples

# Staplers

16 GA Medium Crown Stapler

## LU-851F2



#### Features

- Patented Quick Release Nose Cover
- 360° Adjustable Metal Exhaust
- Heavy Duty, Well Balanced
- Depth Adjustment
- Dedicated Bump Fire Trigger
- Sequential Trigger Available (#25205301A)
- Top Load Long Magazine

#### Fasteners

- Compatible with Hitachi 11200, Omer M2, Senco N Series
- $\square$  .063 x .055" / 1.6 x 1.4mm

#### Applications



#### Tool Specifications

Weight	Dimensions (LxWxH)	Operating Pressure	Load Capacity
2.9 kgs	343 x 97 x 307mm	6 - 8 kg / cm <sup>2</sup>	140 staples
6.5 lbs	13.5 x 3.8 x 12.1"	85 - 110 psi	140 staples

### LU-851F2

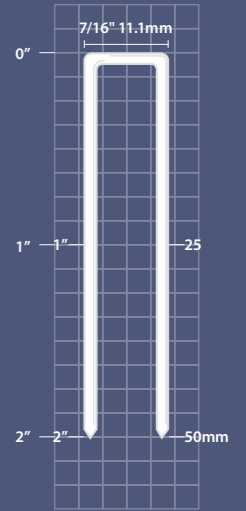

# Staplers

16 GA Medium Crown Stapler-Long Magazine

## LU-851F2-LM



#### Features

- Patented Quick Release Nose Cover
- 360° Adjustable Air Deflector
- Heavy Duty, Well Balanced
- Remote Fire Trigger Available (#15104407A)
- Long Magazine for 5 strips staples(70 staples/strip)

#### Fasteners

- Compatible with Hitachi 11200, Omer M2, Senco N Series
- $\square$  .063 x .055" / 1.6 x 1.4mm

#### Applications



#### Tool Specifications

Weight	Dimensions (LxWxH)	Operating Pressure	Load Capacity
3.5 kgs	726 x 97 x 300mm	6 - 8 kg / cm <sup>2</sup>	350 staples
7.7 lbs	28.6 x 3.8 x 11.8"	85 - 110 psi	350 staples

### LU-851F2-LM

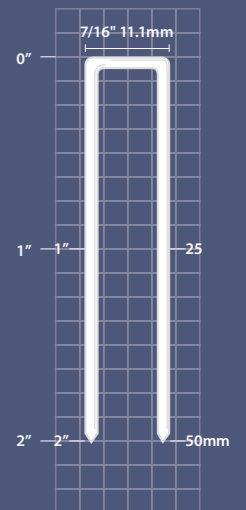

## Staplers

16 GA Medium Crown Stapler

### LU-864F



#### Features

- Patented Quick Release Nose Cover
- 360° Adjustable Air Deflector
- Heavy Duty, Well Balanced
- Sequential Fire Trigger Available (#25205301A)

#### Fasteners

- Compatible with Hitachi 11200, Omer M2, Senco N Series
- $\square$ .063 x .055" / 1.6 x 1.4mm

#### Applications



#### Tool Specifications

Weight	Dimensions (LxWxH)	Operating Pressure	Load Capacity
2.9 kgs	343 x 97 x 307mm	6-8 kg / cm <sup>2</sup>	140 staples
6.5 lbs	13.5 x 3.8 x 12.1"	85-110 psi	140 staples

### LU-864F

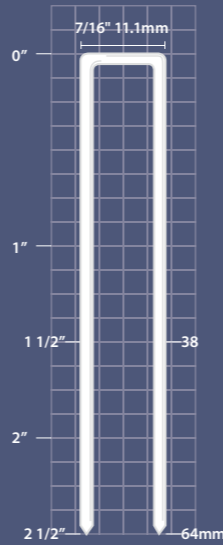

## Staplers

16 GA Medium Crown Stapler

### LU-864KGF



#### Features

- Patented Quick Release Nose Cover
- 360° Adjustable Air Deflector
- Heavy Duty, Well Balanced
- Sequential Fire Trigger Available (#25205301A)

#### Fasteners

- Compatible with Duo-Fast 7600, Haubold KG 700, Omer 700 Series
- $\square$ .063 x .055" / 1.6 x 1.4mm

#### Applications



#### Tool Specifications

Weight	Dimensions (LxWxH)	Operating Pressure	Load Capacity
2.9 kgs	343 x 97 x 307mm	6 - 8 kg / cm <sup>2</sup>	140 staples
6.5 lbs	13.5 x 3.8 x 12.1"	85 - 110 psi	140 staples

### LU-864KGF

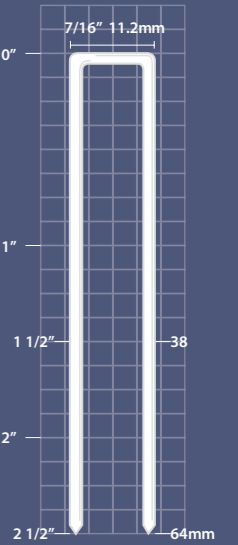

## Staplers

16 GA Medium Crown Stapler

### LU-851KGF2



#### Features

- Patented Quick Release Nose Cover
- 360° Adjustable Air Deflector
- Heavy Duty, Well Balanced
- Sequential Fire Trigger Available (#25205301A)

#### Fasteners

- Compatible with Duo-Fast 7600, Haubold KG 700, Omer 700 Series
- $\square$ .063 x 0.55" / 1.6 x 1.4mm

#### Applications



#### Tool Specifications

Weight	Dimensions (LxWxH)	Operating Pressure	Load Capacity
2.9 kgs	343 x 97 x 307mm	6 - 8 kg / cm <sup>2</sup>	140 staples
6.5 lbs	13.5 x 3.8 x 12.1"	85 - 110 psi	140 staples

### LU-851KGF2

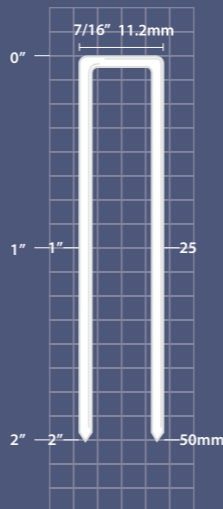

## Staplers

16 GA Medium Crown Stapler

### LU-951F2



#### Features

- Patented Quick Release Nose Cover
- 360° Adjustable Metal Exhaust
- Heavy Duty, Well Balanced
- Sequential Trigger Available (#25205301A)

#### Fasteners

- Compatible with Bostitch BSC4, Max 9T, Omer S4, Prebena S Series
- $\square$ .063 x .055" / 1.6 x 1.4mm

#### Applications



#### Tool Specifications

Weight	Dimensions (LxWxH)	Operating Pressure	Load Capacity
2.9 kgs	343 x 97 x 307mm	6 - 8 kg / cm <sup>2</sup>	140 staples
6.5 lbs	13.5 x 3.8 x 12.1"	85 - 110 psi	140 staples

### LU-951F2

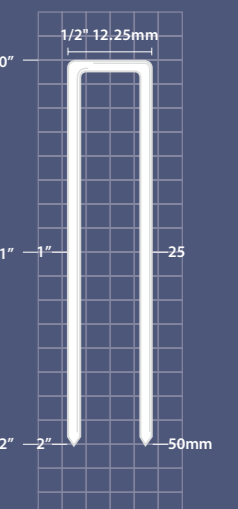

# Staplers

16 GA Medium Crown Stapler



## LU-964F

### Features

- Patented Quick Release Nose Cover
- 360° Adjustable Air Deflector
- Heavy Duty, Well Balanced
- Sequential Fire Trigger Available (#25205301A)

### Fasteners

- Compatible with Bostitch BSC4, Max 9T, Omer S4, Prebena S Series
- $\square$  .063 x .055" / 1.6 x 1.4mm

### Applications



### Tool Specifications

Weight	Dimensions (LxWxH)	Operating Pressure	Load Capacity
2.9 kgs	343 x 97 x 307mm	6 - 8 kg / cm <sup>2</sup>	140 staples
6.5 lbs	13.5 x 3.8 x 12.1"	85 - 110 psi	140 staples

## LU-964F

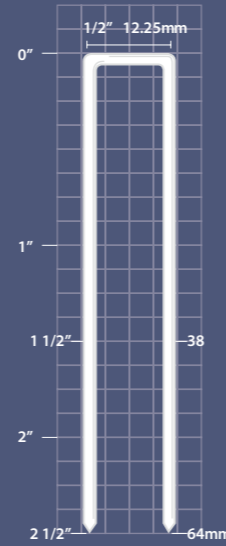

# Staplers

14 GA Wide Crown Stapler Heavy Duty



## LU-1438

### Features

- Patented Quick Release Nose Cover
- 360° Adjustable Air Deflector
- Heavy Adjustable Air Deflector
- Sequential Fire Trigger Available (#25205301A)

### Fasteners

- 14 Gauge Staples
- Compatible with Bostitch 538S214, Paslode 4150-W14, Spotnails MS 2440
- $\emptyset$ .070x .082" / 1.8 x 2.1mm

### Applications



### Tool Specifications

Weight	Dimensions (LxWxH)	Operating Pressure	Load Capacity
3.1 kgs	356 x 95 x 290mm	6 - 8 kg / cm <sup>2</sup>	118 staples
6.82 lbs	14.01 x 3.74 x 11.41"	80 - 110 psi	118 staples

## LU-1438

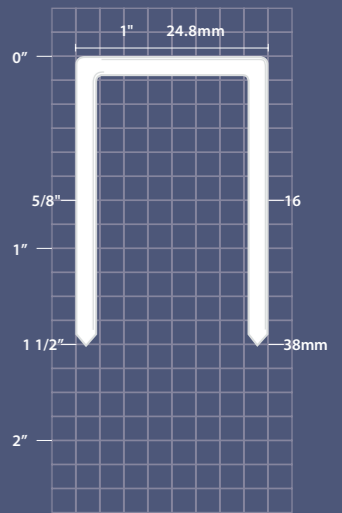

# Staplers

15 GA Medium Crown Stapler



## LU-1580F

### Features

- Patented Quick Release Nose Cover
- 360° Adjustable Air Deflector
- Heavy Duty, Well Balanced
- Sequential Fire Trigger Available (#25205301A)

### Fasteners

- Compatible with Duo-Fast 1500, Haubold 7900, Senco Q Series
- $\square$  .075 x .067" / 1.9 x 1.7mm

### Applications



### Tool Specifications

Weight	Dimensions (LxWxH)	Operating Pressure	Load Capacity
2.9 kgs	343 x 97 x 307mm	6 - 8 kg / cm <sup>2</sup>	140 staples
6.5 lbs	13.5 x 3.8 x 12.1"	85 - 110 psi	140 staples

## LU-1580F

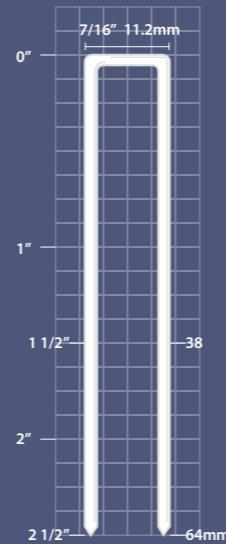

# Staplers

16 GA Wide Crown Stapler Light Duty



## LU-2438.1

### Features

- Patented Quick Release Nose Cover
- 360° Adjustable Metal Exhaust
- Sequential Fire Trigger Available (#34903501A)

### Fasteners

- 16 Gauge Staples
- Compatible with GSW, Paslode Gsw
- $\emptyset$ .063x.055" / 1.6 x 1.4 mm

### Applications



### Tool Specifications

Weight	Dimensions (LxWxH)	Operating Pressure	Load Capacity
2.6 kgs	373 x 70 x 260mm	6 - 8 kg / cm <sup>2</sup>	140 staples
5.2 lbs	14.7 x 2.75 x 10.23"	80 - 110 psi	140 staples

## LU-2438.1

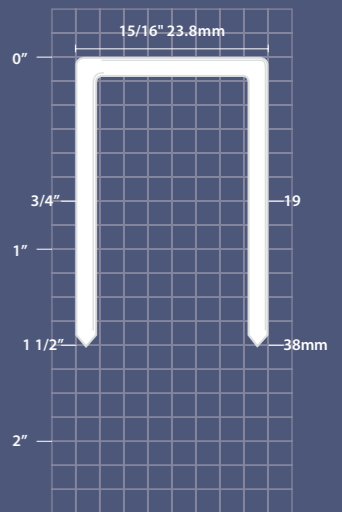

# Staplers

16 GA Walking Stick Stapler

**LU-2438.1-WS**



### Features

- Patented Quick Release Nose Cover
- 360° Adjustable Metal Exhaust
- Swivel Air-nlet for Less Hose Tangling
- Air Trigger Available
- Depth-of-Drive Adjustable

### Fasteners

- 16 Gauge Staples
- Compatible with GSW, Paslode Gsw
- Ø.063x.055" / 1.6 x 1.4 mm

### Applications

- Carton Bos to Pallets
- Container Inserts

### Tool Specifications

Weight	Dimensions (LxWxH)	Operating Pressure	Load Capacity
3.4 kgs	370 x 84 x 880mm	6 - 8 kg / cm <sup>2</sup>	140 staples
7.5 lbs	14.7 x 3.3 x 34.65"	85 - 110 psi	140 staples

LU-2438.1-WS

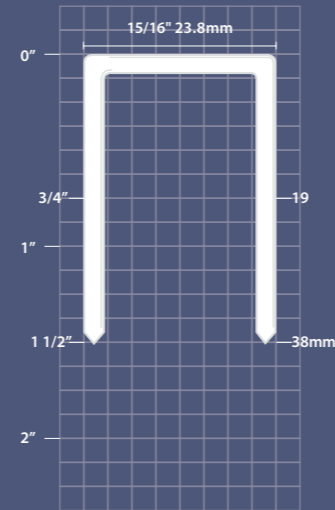

# Staplers

16 GA Wide Crown Stapler  
Light Duty

**LU-2538.1**



### Features

- Patented Quick Release Nose Cover
- 360° Adjustable Metal Exhaust
- Sequential Fire Trigger Available (#34903501A)

### Fasteners

- 16 Gauge Staples
- Compatible with BOSTITCH BCS(16S2), Complete 16S2 Series
- Ø.063 x .055" / 1.6 x 1.4 mm

### Applications



### Tool Specifications

Weight	Dimensions (LxWxH)	Operating Pressure	Load Capacity
2.6 kgs	373 x 70 x 260mm	6 - 8 kg / cm <sup>2</sup>	140 staples
5.2 lbs	14.7 x 2.75 x 10.23"	80 - 110 psi	140 staples

LU-2538.1

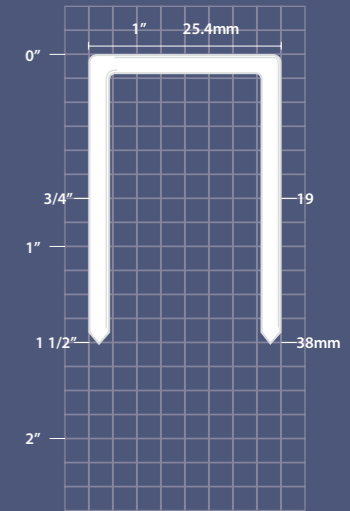

# Staplers

16 GA Walking Stick Stapler

**LU-2538.1-WS**



### Features

- Patented Quick Release Nose Cover
- 360° Adjustable Metal Exhaust
- Swivel Air-nlet for Less Hose Tangling
- Air Trigger Available
- Depth-of-Drive Adjustable

### Fasteners

- 16 Gauge Staples
- Compatible with BOSTITCH(16S2), Complete 16S2 Series
- Ø.063x.055" / 1.6 x 1.4 mm

### Applications

- Carton Bos to Pallets
- Container Inserts

### Tool Specifications

Weight	Dimensions (LxWxH)	Operating Pressure	Load Capacity
3.4 kgs	370 x 84 x 880mm	6 - 8 kg / cm <sup>2</sup>	140 staples
7.5 lbs	14.7 x 3.3 x 34.65"	85 - 110 psi	140 staples

LU-2538.1-WS

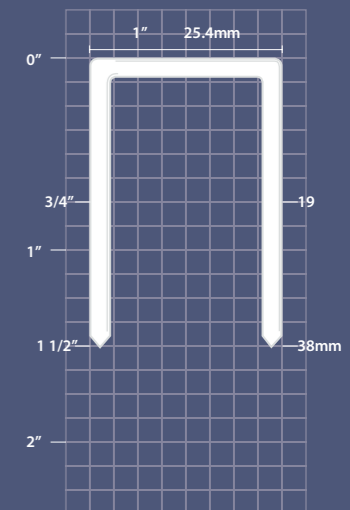

# Staplers

16 GA Wide Crown Stapler  
Heavy Duty



## LU-2538

### Features

- Patented Quick Release Nose Cover
- 360° Adjustable Metal Exhaust
- Heavy Adjustable Air Deflector
- Sequential Fire Trigger Available (#25205301A)

### Fasteners

- 16 Gauge Staples
- Compatible with BOSTITCH BCS(16S2), Complete 16S2 Series
- Ø.063 x .055" / 1.6 x 1.4 mm

### Applications



### Tool Specifications

Weight	Dimensions (LxWxH)	Operating Pressure	Load Capacity
3.1 kgs	356 x 95 x 290mm	6 - 8 kg / cm <sup>2</sup>	118 staples
6.82 lbs	14.01 x 3.74 x 11.41"	80 - 110 psi	118 staples

## LU-2538

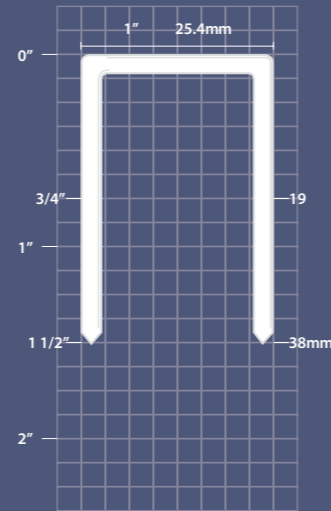

# Staplers

16 GA Walking Stick Stapler



## LU-2638.1-WS

### Features

- Patented Quick Release Nose Cover
- 360° Adjustable Metal Exhaust
- Swivel Air-nlet for Less Hose Tangling
- Air Trigger Available
- Depth-of-Drive Adjustable

### Fasteners

- 16 Gauge Staples
- Compatible with Complete P, Senco PW150R/P, Hitachi N5024A/11300, Duo-Fast RNS-17481/1716 cgr Series
- Ø.063x.055" / 1.6 x 1.4 mm

### Applications

- Carton Bos to Pallets
- Container Inserts

### Tool Specifications

Weight	Dimensions (LxWxH)	Operating Pressure	Load Capacity
3.4 kgs	370 x 84 x 880mm	6 - 8 kg / cm <sup>2</sup>	140 staples
7.5 lbs	14.7 x 3.3 x 34.65"	85 - 110 psi	140 staples

## LU-2638.1-WS

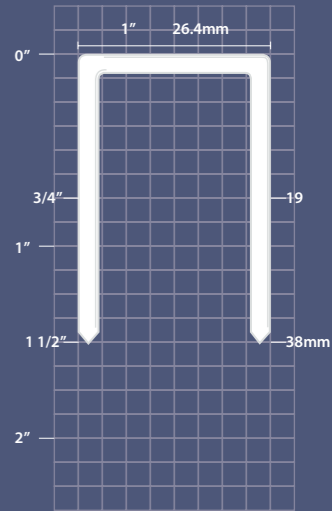

# Staplers

16 GA Wide Crown Stapler  
Light Duty



## LU-2638.1

### Features

- Patented Quick Release Nose Cover
- 360° Adjustable Metal Exhaust
- Sequential Fire Trigger Available (#34903501A)

### Fasteners

- 16 Gauge Staples
- Compatible with P, Senco PW150R/P, Hitachi N5024A/11300, Duo-Fast RNS-17481/1716 cgr Series
- Ø.063 x .055" / 1.6 x 1.4 mm

### Applications



### Tool Specifications

Weight	Dimensions (LxWxH)	Operating Pressure	Load Capacity
2.6 kgs	373 x 70 x 260mm	6 - 8 kg / cm <sup>2</sup>	140 staples
5.2 lbs	14.7 x 2.75 x 10.23"	80 - 110 psi	140 staples

## LU-2638.1

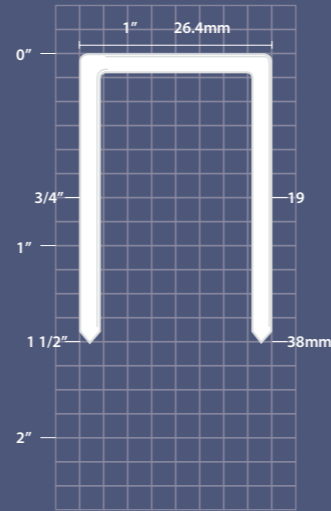

# Staplers

16 GA Wide Crown Stapler  
Heavy Duty



## LU-2638

### Features

- Patented Quick Release Nose Cover
- 360° Adjustable Metal Exhaust
- Heavy Adjustable Air Deflector
- Sequential Fire Trigger Available (#25205301A)

### Fasteners

- 16 Gauge Staples
- Compatible with Complete P, Senco PW150R/P, Hitachi N5024A/11300, Duo-Fast RNS-17481/1716 cgr Series
- Ø.063 x .055" / 1.6 x 1.4 mm

### Applications



### Tool Specifications

Weight	Dimensions (LxWxH)	Operating Pressure	Load Capacity
3.1 kgs	356 x 95 x 290mm	6 - 8 kg / cm <sup>2</sup>	140 staples
6.82 lbs	14.01 x 3.74 x 11.41"	80 - 110 psi	140 staples

## LU-2638

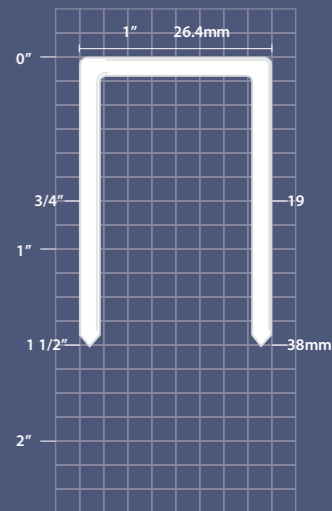

## Staplers - Fine Wire



Wire Gauge	Staple Type	F Series up to 16mm	AC Series up to 16mm	LAC Series up to 16mm	Auto series up to 16mm	AC series up to 25mm
23	SJK	LU-SJK16				
23	71	LU-7116F	LU-7116AC	LU-7116LAC	LU-7116.1AUTO LU-7116.1AUTO/LM	
23	14		LU-1416AC			
23	23	LU-2316F				
21	97	LU-9716F				LU-9725AC
21	98					
21	84		LU-8416AC			
21	80	LU-8016F	LU-8016AC.1	LU-8016LAC	LU-8016.1AUTO LU-8016.1AUTO/LM	LU-8025AC
20	4J					LU-425JAC
20	10J	LU-1016J			LU-1016AUTO	LU-1025JAC
22	10F	LU-1016F				
20	50		LU-5018AC			

## Staplers - Medium Wire



Wire Gauge	Staple Type	up to 25mm	up to 32mm	up to 40mm Light Duty	up to 40mm Heavy Duty	up to 40mm Heavy Duty
18	90	LU-9025AC	LU-9032AC	LU-9040LAC	LU-9040HAC	LU-9040KT
18	92	LU-9225AC	LU-9232AC	LU-9240LAC	LU-9240HAC	
18	G	LU-G25AC	LU-G32HAC	LU-G40LAC		
18	500			LU-50040LAC		
18	94			LU-9438AC		

## Staplers - Heavy Wire



Wire Gauge	Staple Type	Light Duty up to 50mm	Heavy Duty up to 50mm	Heavy Duty up to 64mm
17	O	LU-851LC1		
16	N	LU-851LC1	LU-851F2/ILU-851F2LM	LU-864F
16	KG		LU-851KGF2	LU-864KGF
16	9		LU-951F2	LU-964F
15	Q			LU-1580F



Specialty p59 - 69

# Pneumatic Hog Ring Tools

**LPHC**



## Features

- Available in Short (S = 25mm), Medium (M = 40mm) and Long (L = 48mm) Nose Working Length for Different Applications
- Comfortable Ergonomic Rubber Handle
- Light Weight and Well Balanced
- Adjustable Exhaust Deflector
- Steel Casted Trigger for Enhanced Durability
- Low Noise

## Applications

- Bag Closure
- Cage Grid Secure
- Auto Seat
- Wire Mesh Closure
- Label Attachment
- Spring Bed / Mattress

## Model coding system:

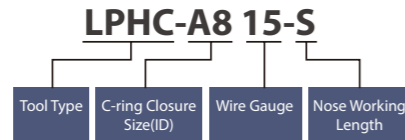

## Tool Specifications

Model	WL	C-Ring Type			Tool Weight	Magazine Capacity	Similar to Meihotech	Similar to Stanley
LPHC-A815-S	25mm 1"	Ø 1.8mm .070"	19mm 3/4"	7.9 - 10.7mm 5/16 - 13/32"	1.40 kgs 0.64 lbs	100 pcs	MC-6, MC-6LW	SC7
LPHC-A815-M	40mm 9/16"	15 Gauge 15G100			1.45 kgs 0.66 lbs		MC-6LNA, MC-6LNALW	SC7E
LPHC-A815-L	48mm 2"				1.50 kgs 0.68 lbs			SC77XE
LPHC-A515-S	25mm 1"				19mm 3/4"		4.8 - 8.7mm 3/16 - 11/32"	1.40 kgs 0.64 lbs
LPHC-A816-S	25mm 1"	Ø 1.6mm .063"	19mm 3/4"	7.9 - 10.7mm 5/16 - 13/32"	1.40 kgs 0.64 lbs	110 pcs		
LPHC-A816-M	40mm 9/16"	16 Gauge 16G110			1.45 kgs 0.66 lbs			
LPHC-A816-L	48mm 2"				1.50 kgs 0.68 lbs			
LPHC-A516-S	25mm 1"		19mm 3/4"	4.8 - 8.7mm 3/16 - 11/32"	1.40 kgs 0.64 lbs			SC743
LPHC-C316-S	25mm 1"	Ø 1.6mm .063"	12.5mm 1/2"	3.2 - 5.6mm 1/8 - 7/32"	1.40 kgs 0.64 lbs	100 pcs	MC-660	SC760

# Pneumatic Hog Ring Tools

**LPHCN**



## LPHC Series Tools Conventional C Ring Style

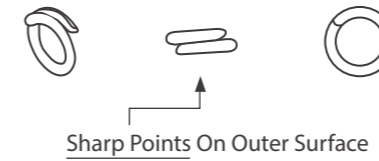

## LPHCN Series Tools New C Ring Style

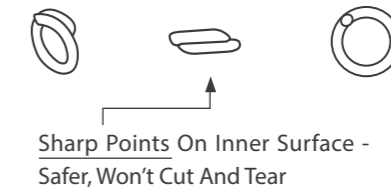

Model	WL	C-Ring Type			Tool Weight	Magazine Capacity	Similar to Meihotech	Similar to Stanley
LPHCN-A815-S	25mm 1"	Ø 1.8mm .070"		7.9 - 10.7mm 5/16 - 13/32"	1.40 kgs 0.64 lbs	100 pcs		
LPHCN-A815-M	40mm 9/16"	15 Gauge 15G100N	19mm 3/4"		1.45 kgs 0.66 lbs			
LPHCN-A815-L	48mm 2"				1.50 kgs 0.68 lbs			

# Mattress Stapler **MS-1619**

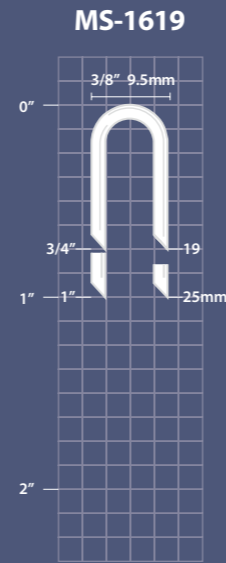

### Features

- Drives Staples into Hard-To-Reach Places Such as Bottom of Coil Springs
- Powerful and Quick Fastener Placement
- Single or Double Staple Fire Versions Available: Single Staple: Shoots 1 Staple Per Cycle  
Double Staple: Shoots 2 Staples Per Cycle, for Increased Efficiency of Staple Placement
- Tools Available:

Model	Staples used	Firing Version
MS-1619	19mm	Double Staple
MS-1619S	19mm	Single Staple
MS-1625	19 & 25mm	Double Staple
MS-1625S	19 & 25mm	Single Staple

### Fasteners

- U-Crown Diversion Points Staples
- Similar to Bostitch BSC31
- $\square$  .062 x .057" (1.6 x 1.4mm)

### Applications

- Bedding
- Spring-Up
- Assembly

### Tool Specifications

Weight	Dimensions (LxWxH)	Operating Pressure	Load Capacity
3.5 kgs	470 x 35 x 830mm	5 - 7 kg / cm <sup>2</sup>	180 staples
7.7 lbs	18.5 x 1.4 x 32.7"	70 - 100psi	180 staples

# Nail Puncher **NP-50**



### Features

- Powerful
- Fast for Increased Efficiency

### Fasteners

- Length: 25 - 57mm (1- 2 1/4")
- $\varnothing$ : .083 - .090" (2.1 - 2.3mm)

### Applications

- Remove Nails from Wood for Pallet Recycling

### Tool Specifications

Weight	Dimensions (LxWxH)	Operating Pressure	Load Capacity
1 kgs	245 x 65 x 225mm	5 - 6kg / cm <sup>2</sup>	1
2.2 lbs	9.7 x 2.6 x 8.9"	70 - 85 psi	1

# Nail Puncher **NP-57E**



### Features

- Powerful
- Fast for Increased Efficiency

### Fasteners

- Length: 25 - 57mm (1" - 2 1/4")
- $\varnothing$ : .083 - .090" (2.1 - 2.3mm)

### Applications

- Remove Nails from Wood for Pallet Recycling

### Tool Specifications

Weight	Dimensions (LxWxH)	Operating Pressure	Load Capacity
1.8 kgs	263 x 282 x 100mm	5 - 6 kg / cm <sup>2</sup>	1
4.0 lbs	10.4 x 11 x 3.9"	70 - 85 psi	1

# Nail Puncher

**NP-70E**



### Features

- Powerful
- Fast for Increased Efficiency

### Fasteners

- Length: 1 3/4 - 2 3/4" (45 - 70mm)
- Ø: .099 - .113" (2.5 - 2.9mm)

### Applications

- Remove Nails from Wood for Pallet Recycling

### Tool Specifications

Weight	Dimensions (LxWxH)	Operating Pressure	Load Capacity
2.6 kgs	295 x 305 x 120mm	5 - 6 kg / cm <sup>2</sup>	1
5.7 lbs	11.6 x 12 x 4.7"	70 - 85 psi	1

# Corrugated Fastener Tool

**CF-15AA**



### Features

- Bottom Load Magazine
- Easy Magazine Adjustment
- Jam-Free Magazine
- Powerful

### Fasteners

- Compatible with Bea W, Duo-Fast CF, Haubold WN, Senco SC2, Omer CF Series

### Applications



### Tool Specifications

Weight	Dimensions (LxWxH)	Operating Pressure	Load Capacity
2.7 kgs	286 x 94 x 312mm	5.5 - 7kg / cm <sup>2</sup>	100 fasteners
5.95 lbs	11.3 x 3.7 x 12.3"	80 - 100 psi	100 fasteners

CF-15AA Senco Type

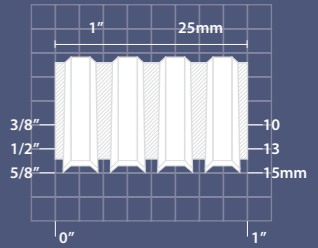

# Corrugated Fastener Tool

**CF-15AP**



### Features

- Bottom Load Magazine
- Easy Magazine Adjustment
- Jam-Free Magazine
- Powerful

### Fasteners

- Compatible with Paslode Series

### Applications



### Tool Specifications

Weight	Dimensions (LxWxH)	Operating Pressure	Load Capacity
2.7 kgs	286 x 94 x 312mm	5.5 - 7kg / cm <sup>2</sup>	100 fasteners
5.95 lbs	11.3 x 3.7 x 12.3"	80 - 100 psi	100 fasteners

CF-15AP Paslode Type

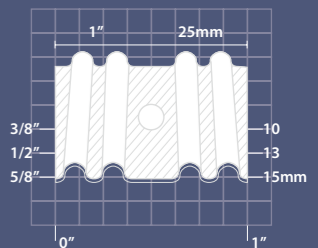

# Palm Nailer

**PTS-8400**



### Features

- Cost Saving
- Ergonomic Handle
- Multiple Impact
- Leather Glove Available for Enhanced Comfort

Suggested Air Pressure for Different Range of Nail Sizes:

Nail size		Air pressure	
mm	inch	kg / cm <sup>2</sup>	psi
20 - 25	3/4 - 1"	3.5 - 5.5	50 - 80
25 - 38	1 - 1 1/2"	5.5 - 7.0	80 - 100
38 - 165	1 1/2 - 6 1/2"	7.0 - 8.0	100 - 120

### PTS-8400 KIT Accessories Include:

- Plastic Carry Case
- (L) Magnetized Guide Tip Unit - for Nail Head Ø Up to 10mm
- (S) Magnetized Guide Tip Unit - for Nail Head Ø Up to 5mm
- Magnetized Guide Tip Unit
- Guide Tip - for Larger Diameter Nails or Buttons for Bags or Leather Goods
- Steel Hammer Unit
- Rubber Hammer Unit
- Chisel Unit
- Leather Glove for Enhanced Comfort
- Maintenance Kits-O-Rings, Wrenches and Oil

### Applications



### Tool Specifications

Weight	Dimensions (LxWxH)	Operating Pressure	Load Capacity
1 kgs	124 x 86 x 134mm	3.5 - 8 kg / cm <sup>2</sup>	1
2.2 lbs	4.9 x 3.4 x 5.3"	50 - 120 psi	1

PTS-8400

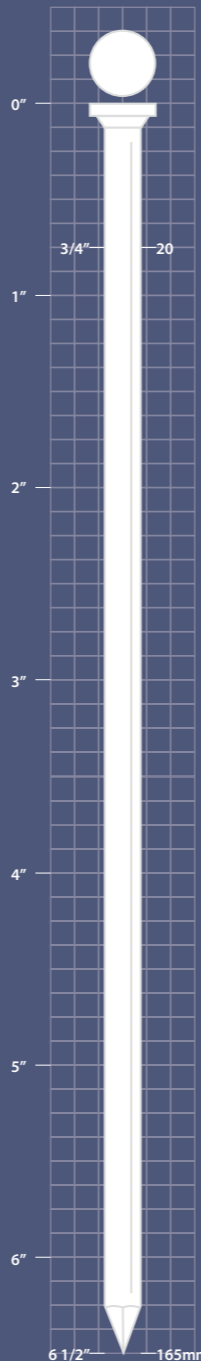

# Metal Connector Nailer

**AMC-38**



### Features

- Light Weight, Impact Design to Reach The Tightest Corners
- Nail Point Sticks Out for Accurate Metal Connector Hole Aiming and Fastening
- Sequential Trigger for Precise Nail Placement
- Swivel Belt Hook for Both Left And Right-Handed Users
- Over-Molded Rubber Grip for Added Comfort and Less Fatigue
- Floating Pusher for Quick Re-Loading of Nails
- Dry-Fire Lock to Prevent Un-Intended Nailing
- 360° Adjustable Exhaust Deflector
- Swivel Air-Inlet for Less Hose Tangling

### Fasteners

- 34° Paper Tape Round Head Nails
- Ø: .131 - .162" / 3.3 - 4.1mm

### Applications

- Joist Hangers
- Metal Connectors

### Tool Specifications

Weight	Dimensions (LxWxH)	Operating Pressure	Load Capacity
2.25 kgs	365 x 90 x 295mm	5.5 - 7 kg / cm <sup>2</sup>	29 nails
4.95 lbs	14 3/8 x 3 1/2 x 11 5/8"	80 - 100 psi	29 nails

# Stapler

2-in-1 Medium & Narrow Crown Stapler for Polymer

**LU-8016FP**



### Features

- Hammer Cap
- Bottom Load, Jam Free Magazine
- Rear Exhaust Cover
- Slim Long Nose for Easy Aiming
- Accepts Both Narrow & Medium Polymer Staples

### Fasteners

- 1/2" (12.7mm) & 3/8" (10mm) Crown Polymer Staples

### Applications

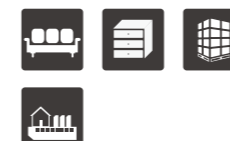

### Tool Specifications

Weight	Dimensions (LxWxH)	Operating Pressure	Load Capacity
0.88 kgs	219 x 43 x 144mm	4 - 7 kg / cm <sup>2</sup>	75 - 80 Staples
1.95 lbs	8.6 x 1.7 x 5.7"	60 - 100 psi	75 - 80 Staples

AMC-38

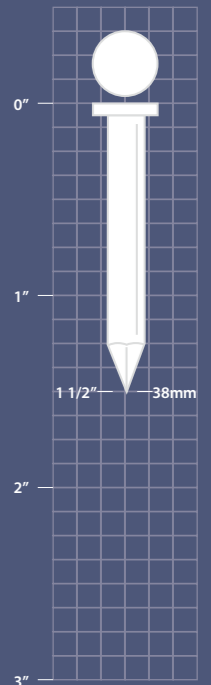

LU-8016FP

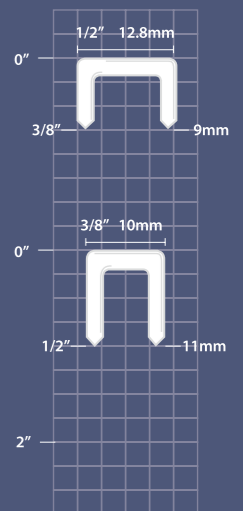

# Specialty

Pneumatic Clinch Nailer

## CN-70CL



CN-70CL

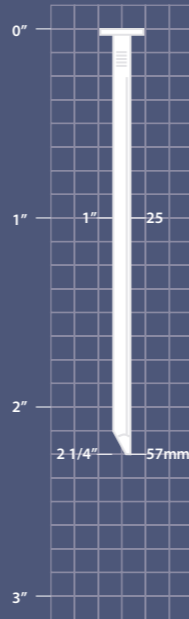

### Features

- Ergonomic Design, Ideal for Pallet Repairs
- Powerful, Rapid Nailing Performance
- Well Protectors Equipped
- Top Exhaust Cap Available

### Fasteners

- 15° Flat Wire Collated Clinch Nails
- Length: 1-3/4"~2-1/4"(45-57mm)
- Shank Diameter :.090-.113"(2.3-2.9 mm)
- Shank Type : Smooth, Ring & Screw

### Tool Specifications

Weight	Dimensions (LxWxH)	Operating Pressure	Load Capacity
7.6 kgs	370 x 148 x 400mm	5 - 7 kg / cm <sup>2</sup>	225-300 nails
16.76 lbs	14.6 x 5.83 x 15.75"	70 - 100 psi	225-300 nails

### Applications



# Specialty

## Autotec Modular Nailers

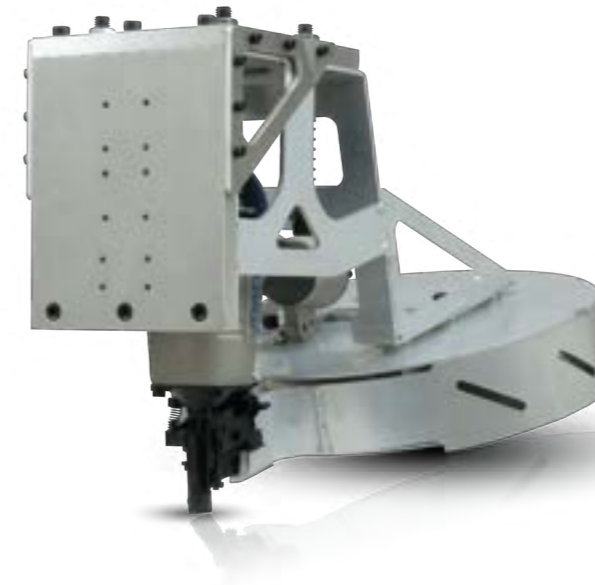

### Features

- Powerful, Applicable automatic arm robot system
- High magazine capacity
- Durable metal frame
- Customized design
- Automatic remote control trigger valve

### Fasteners

- 15 Degree Jumbo coil nails
- Length:
  - 13/4" - 2 1/4" (45 - 57 mm) for CN-57E-RBM
  - 1 3/4" - 2 3/4" (45 - 70 mm) for CN-70E-RBM
  - 1 3/4" - 3 1/4" (45 - 83 mm) for CN-83E-RBM
- Shank Diameter:
  - .083 - .090" (2.1 - 2.3 mm) for CN-57E-RBM
  - .090 - .113" ( 2.3- 2.9 mm) for CN-70E-RBM
  - .099 - .131" ( 2.5 - 3.3 mm) for CN-83E-RBM

### Applications

- Working on automated pallet machine
- Assembly pallets, drums, export wooden boxes

### Tool Specifications

Model	Weight	Operating Pressure	Load Capacity
CN-57E-RBM	10.0 kgs	5.6 - 7 kg / cm <sup>2</sup>	Coil Max.OD≤350mm 2,000-3,000 nails
CN-70E-RBM	10.7 kgs	5.6 - 7 kg / cm <sup>2</sup>	Coil Max.OD≤350mm 2,000-3,000 nails
CN-83E-RBM	11.0 kgs	5.6 - 7 kg / cm <sup>2</sup>	Coil Max.OD≤350mm 2,000-3,000 nails

CN-57E-RBM

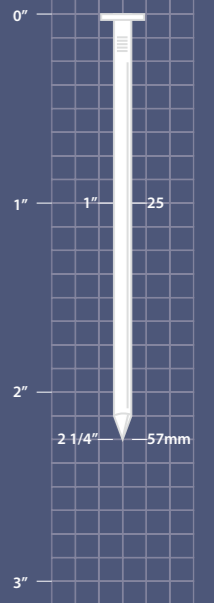

CN-70E-RBM

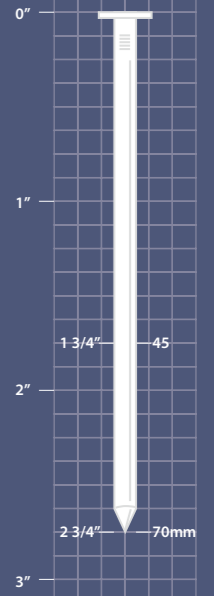

CN-83E-RBM

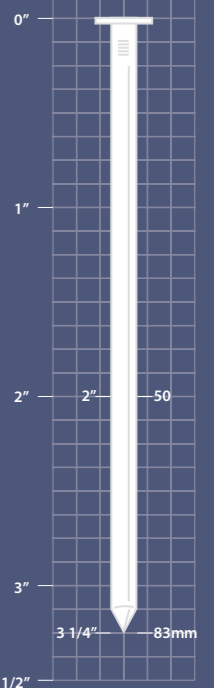



p70-76 **Carton Closing**

## Carton Closing Staplers

### Strip Series



#### ▲ Features

- Ergonomic Handle
- Light Weight and Well Balanced
- Depth of Clinch and Penetration Adjustable
- Raised Top Cap for Enhanced Durability
- Low Noise

#### ▲ Fasteners

Model	Staple Type	Crown	Length	Shank Diameter
CS-19A	A strip	34.7mm 1 3/8"	15 & 18mm 5/8 & 3/4"	2.3 x 0.9mm .090 x .037"
CS-19C	C strip	32mm 1 1/4"	15 & 18mm 5/8 & 3/4"	1.9 x 0.9mm .074 x .037"
CS-19SW	SW7437 strip	34.5mm 1 3/8"	15 & 18mm 5/8 & 3/4"	1.9 x 0.9mm .074 x .037"
CS-22A	A strip	34.7mm 1 3/8"	18 & 22mm 3/4 & 7/8"	2.3 x 0.9mm .090 x .037"
CS-22C	C strip	32mm 1 1/4"	18 & 22mm 3/4 & 7/8"	1.9 x 0.9mm .074 x .037"
CS-229040	9040 strip	34.5mm 1 3/8"	18 & 22mm 3/4 & 7/8"	2.3 x 0.9mm .090 x .037"

#### ▲ Manual Tools

Model	Staples Type	Length
MCS-19A	A strip	15 & 18mm
MCS-19C	C strip	5/8 & 4/3"
MCS-19SW	SW7437 strip	

#### ▲ Tool Specifications

Weight	Dimensions (LxWxH)	Operating Pressure	Load Capacity
2.0 kgs	335 x 115 x 220mm	5 - 7 kg / cm <sup>2</sup>	100
4.4 lbs	13 1/8 x 4 1/2 x 8 5/8"	70 - 100psi	100



## Carton Closing Staplers

### Strip Series



ACS-15C/ACS-18C

AMS-15C/AMS-18C

#### Features

- C strip Staple Type
- Ergonomic Handle
- Light Weight and Well Balanced
- Raised Top Cap for Enhanced Durability
- Long Magazine for 150 Staples
- Two-piece magazine design more durable

#### Fasteners

Model	Staple Type	Crown	Length	Shank Diameter
ACS-15C	C Strip	32 mm 1 1/4"	15 mm 5/8"	1.9x0.9 mm .074 x .037"
ACS-18C	C Strip	32 mm 1 1/4"	18 mm 3/4"	1.9x0.9 mm .074 x .037"
AMS-15C	C Strip	32 mm 1 1/4"	15 mm 5/8"	1.9x0.9 mm .074 x .037"
AMS-18C	C Strip	32 mm 1 1/4"	18 mm 3/4"	1.9x0.9 mm .074 x .037"

#### Tool Specifications

Model	Weight	Dimensions (LxWxH)	Operating Pressure	Load Capacity
ACS-15C	2.4 kgs	530 x 90 x 320mm	5 - 7 kg/cm <sup>2</sup>	150 staples
ACS-18C	5.3 lbs	20.8 x 3.5 x 12.6"	70 - 100 psi	150 staples
AMS-15C	2.5 kgs	420 x 90 x 129mm	5 - 7 kg/cm <sup>2</sup>	150 staples
AMS-18C	5.5 lbs	16.5 x 3.5 x 8.5"	70 - 100 psi	150 staples

## Carton Closing Staplers

### Coil Series

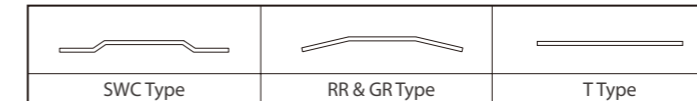

#### Features

- Ergonomic Handle
- Light Weight and Well Balanced
- Ideal for High Volume and Efficient Applications
- Quick Release to Prevent Jams
- Tightness and Depth of Clinch Adjustable
- Raised Top Cap for Enhanced Durability
- Low Noise

#### Fasteners

Model	Staple Type	Crown	Length	Shank Diameter
CCS-19SWC	SWC Coil	34.5mm 1 3/8"	15 & 18mm 5/8 & 3/4"	1.9 x 0.9mm .074 x .037"
CCS-19RR	RR1 Coil	32mm 1 1/4"	15 & 18mm 5/8 & 3/4"	1.9 x 0.9mm .074 x .037"
CCS-19GR	GR1 Coil	32mm 1 1/4"	15 & 18mm 5/8 & 3/4"	2.3 x 0.9mm .090 x .037"
CCS-22GR	GR1 Coil	32mm 1 1/4"	18 & 22mm 3/4 & 7/8"	2.3 x 0.9mm .090 x .037"
CCS-19T	T Coil	32mm 1 1/4"	15 & 18mm 5/8 & 3/4"	1.9 x 0.9mm .074 x .037"

#### Tool Specifications

Weight	Dimensions (LxWxH)	Operating Pressure	Load Capacity
2.4 kgs	233 x 115 x 230mm	5 - 7 kg / cm <sup>2</sup>	1000
5.28 lbs	9 1/8 x 4 1/2 x 9"	70 - 100psi	1000

## Pneumatic Foot Bottomers

### LPB & LPS Series



LPB Bottomers

LPS Side Bottomers

#### Features

- Suggested for High Volume Production Outputs – 50 to 100 Carton Bottoms Per Hour
- Equipped with A Safety Foot Pedal

#### Fasteners

Bottomers	Side Bottomers	Staple Type	Crown	Length
LPB-19SW	LPS-19SW	SW7437 strip	34.5mm 1 3/8"	15 & 18mm 5/8 & 3/4"
LPB-22A	LPS-22A	A strip	34.7mm 1 3/8"	15, 18 & 22mm 5/8, 3/4 & 7/8"
LPB-22C	LPS-22C	C strip	32mm 1 1/4"	15, 18 & 22mm 5/8, 3/4 & 7/8"
LPB-229040	LPS-229040	9040 strip	34.5mm 1 3/8"	15, 18 & 22mm 5/8, 3/4 & 7/8"

#### Tool Specifications

Weight	Dimensions (LxWxH)	Operating Pressure	Load Capacity
22.7 kg	830 x 600 x 1245mm	5.5 - 6kg/cm <sup>2</sup>	200
50 lbs	32.6 x 23.6 x 49"	80 - 85 psi	200

#### Mechanical Foot Bottomers Are Also Available:

Bottomers	Side Bottomers	Staple Type
LMB-19SW	LMS-19SW	SW7437 strip
LMB-22A	LMS-22A	A strip
LMB-22C	LMS-22C	C strip
LMB-229040	LMS-229040	9040 strip

## Jumbo Carton Closing Staplers

### Jumbo Series



#### Features

- Comfortable Rubber Grip
- Rear Exhaust
- Trigger Actuated
- Depth of Clinch and Penetration Adjustable
- Designed for Tri-Wall Corrugated Cardboards (15 - 24mm Total Thickness)

#### Fasteners

Model	Similar to	Crown Size	Shank Diameter	Leg Length	Load Capacity
CJ-25	Bostitch SW9060	32mm 1 1/4"	2.3 x 1.4mm .090 x .060"	25mm 1"	100
CJ-32	Bostitch SW9060	32mm 1 1/4"	2.3 x 1.4mm .090 x .060"	28, 32, 35mm 1 1/8, 1 1/4, 1 3/8"	100
CJ-38	Bostitch SW9060	32mm 1 1/4"	2.3 x 1.4mm .090 x .060"	38mm 1 1/2"	100

#### Tool Specifications

Weight	Dimensions (LxWxH)	Operating Pressure
6 kgs	360 x 174 x 335mm	5 - 7 kg / cm <sup>2</sup>
13.2 lbs	14 1/8 x 6 7/8 x 13 1/8"	70 - 100psi

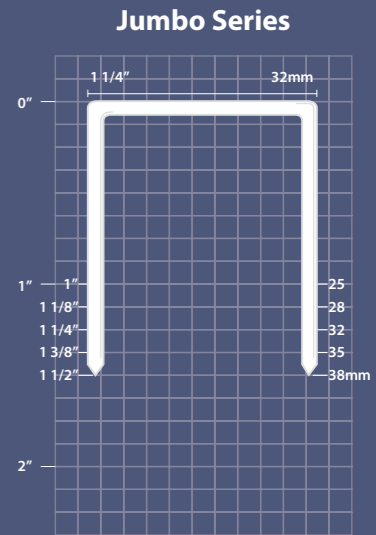

Jumbo Series

## Specialty Tools

### Pneumatic Stapling Pliers



CL Anvil

#### Features

- Powerful Shuttle Blade Provides Pre-Compression Prior to and During The Stapling Operating - Giving A Strong, Tight Closure Without Breaking The Corrugated Surface
- 6" x 1" High Throat Allows Flexibility of Staple Placement and Limits Interference from Obstacles Such As Box Flanges
- C Anvils (CL or CR Available for Sealing Partial Overlap Cartons)
- Penetrates and Securely Fastens up to 2 Thicknesses of Double-Wall:
  - 2x AB Flute or 4x C Flute Boards (A Flute = 3/16" or 4.8mm Thick)
  - (B Flute = 1/8" or 3.2mm Thick)
  - (C Flute = 5/32" or 4.0mm Thick)

#### Fasteners

Tools	Staple Type	Similar to	Crown Size	Shank Diameter	Leg Length	Load Capacity
SP50-10B-A	SB 103020	Bostitch SB 103020	12.95mm 1/2"	0.50 x 2.60mm .020 x .103"	10, 12, 15mm 3/8, 1/2, 5/8"	102
SP50-5B-A	SB 5019	Bostitch SB 5019	12.85mm 1/2"	0.48 x 1.25mm .019 x .050"	6, 10, 12, 15mm 1/4, 3/8, 1/2, 5/8"	108
SP50-777-A	777	JK 777	12.3mm 1/2"	0.65 x 2.25mm .026 x .090"	10, 12, 15mm 3/8, 1/2, 5/8"	140
SP50-779-A	779	JK 779	12.3mm 1/2"	0.63 x 1.3mm .025 x .050"	8, 10, 12, 14, 16mm 5/16, 3/8, 1/2, 9/16, 5/8"	250

#### Applications

- Corrugated Containers
- Trays & Lids
- End Caps
- Headers & Bags
- Container Inserts
- Bedding

#### Tool Specifications

Weight	Dimensions (LxWxH)	Operating Pressure
2.2 kg	370 x 55 x 240mm	2.5 - 3.9kg/cm <sup>2</sup>
4.8 lbs	14 1/2 x 2 1/8 x 9 1/2"	36 - 55 psi

SP103020

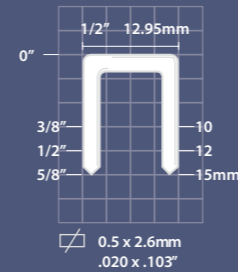

SB5019

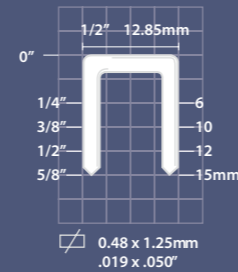

777

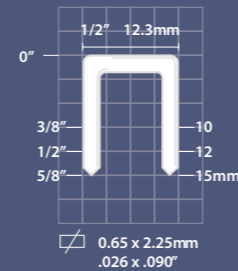

779

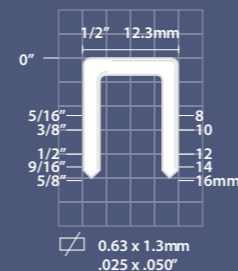

## Accessories

### Hose Reels



#### Features

- Material: Polyurethane Braid Hose
- Maximum Working Pressure: 220PSI / 15BAR
- Working Temperature: -20° C to +60° C
- Features: 360° Rotary Base for High Efficiency

#### Hose Reels

Model	Hose Size MM	Hose Size Inch	Hose Length MM	Hose Length Feet
HR026530	6.5	1/4	30	100
HR026550	6.5	1/4	50	165
HR028020	8.0	5/16	20	66
HR028030	8.0	5/16	30	100
HR028040	8.0	5/16	40	132
HR028520	8.5	11/32	20	165
HR028530	8.5	11/32	30	100
HR029520	9.5	3/8	20	66
HR029530	9.5	3/8	30	100
HR021020	10.0	13/32	20	66

#### Bulk Hoses

Item	Hose Size (IDxOD)	Length (M)
PUB-050800	5 x 8mm	10, 20, 30, 50, 100
PUB-065100	6.5 x 10mm	10, 20, 30, 50, 100
PUB-080120	8 x 12mm	10, 20, 30, 50, 100
PUB-085125	8.5 x 12.5mm	10, 20, 30, 50, 100
PUB-100150	10 x 15mm	10, 20, 30, 50, 100
PUB-110160	11 x 16mm	10, 20, 30, 50, 100
PUB-130190	13 x 19mm	10, 20, 30, 50, 100

All Size of Re-coil Hoses Are Also Available.  
Contact Our Customer Service for More Information.



2025.08

**APACH INDUSTRIAL CO., LTD.**

176 Industrial 9th Rd., Tali Dist.,  
Taichung City, Taiwan 41280  
Tel +886 4 2491 5576  
Fax +886 4 2491 5580  
[www.apach-tools.com](http://www.apach-tools.com)

**DISTRIBUTOR**

